



extreme engineering.com

Mobile Climbing Wall Owner's Manual



Extreme Engineering
9198-B Ridge Road
Newcastle, CA 95658

Voice: 916-663-1560
Fax: 916-663-9249
e-mail: info@extremeengineering.com
Website: www.extremeengineering.com

Revision 7.03
October 2013

© 1995 - 2013 Extreme Engineering®

All Rights Reserved

This manual is the property of Extreme Engineering. Any duplication without Extreme Engineering written consent is illegal. If you have any questions about the manual, please contact Extreme Engineering.

**THANK YOU FOR PURCHASING AN EXTREME ENGINEERING® PRODUCT, THE BEST
MOBILE CLIMBING WALLS ON THE MARKET!**

Extreme Engineering® is a US registered trademark of Extreme Engineering®.

US PAT# 6,083,142, 6,390,952 and patents pending

US Patents and Patents Pending. Extreme Auto-belay™, Belay in the Box™, PowerBelay™, Space Saver™, C.A.T.T.™, Monkey Motion™, Angel Auto-belay™, Speed Harness™, Quad Pod™ and Extreme Air™ are trademarks of Extreme Engineering®.

Congratulations!

Congratulations on your purchase of an Extreme Engineering Mobile climbing wall. Your mobile climbing wall has been designed and engineered by the company who invented and innovated numerous recreational equipment products including: mobile and stationary climbing walls, the Extreme Auto-belay™ safety climbing system, the PowerBelay™ safety rappelling system.

Your mobile climbing wall is the best in the industry!

If you have purchased one of Extreme Engineering's Three-Climber, Four-Climber or Five-Climber mobile climbing walls, your mobile climbing wall utilizes the Extreme Engineering Space Saver™ trailer design. This means, when the wall is raised up for operation, the footprint remaining on the ground is approximately half of the overall length of the wall when it is in the down position.



The Five-Climber model shown includes optional dual toolboxes.

Extreme Engineering® mobile climbing walls are designed with safety, ease of operation and durability built in. It will provide you with years of service.

Your mobile climbing wall is easy to tow, set up, operate and take down. If you follow these instructions carefully and completely, you'll be assured of safe and reliable operation.

Be sure to read and follow all safety instructions found in this manual.

Table of Contents

To jump to a particular section click on the section title.

| | |
|---|-----------|
| 1. Safety first! Read Before Proceeding | 8 |
| 1.1. Safety Rules | 8 |
| 2. Pre-Travel Checklist | 10 |
| 2.1. Tow Vehicle Safety Check | 10 |
| 2.2. Mobile Wall Safety Check | 11 |
| 3. Prepare for Towing Pre Travel Checklist | 11 |
| 3.1. Attach Mobile Wall To Tow Vehicle | 12 |
| 3.2. Pre-Travel Safety Inspection Details | 16 |
| 4. Mobile climbing wall Setup | 26 |
| 4.1. Position Mobile climbing wall | 26 |
| 4.2. Unhitch Tow Vehicle | 26 |
| 4.3. Prepare The Wall For Raising | 27 |
| 4.4. Stabilizer Cable Setup | 30 |
| 4.5. Prepare The Auto-belays | 32 |
| 4.6. Raise The Wall | 34 |
| 4.7. Prime Before You Climb | 37 |
| 5. Prepare For Operating The Wall | 40 |
| 6. Banner Setup | 40 |
| 7. Operating The Wall | 43 |
| 7.1. Operating Techniques | 43 |
| 7.2. Safety Rules For The Operator | 44 |
| 7.3. Safety Rules For Climbers | 44 |
| 7.4. Special Climber Situations | 46 |
| 8. End Of Event Takedown | 47 |
| 8.1. Lower The Wall | 47 |
| 8.2. Prepare The Wall For Transport | 50 |
| 9. Troubleshooting | 50 |
| 10. Frequently Asked Questions | 51 |
| 11. Maintenance | 54 |

Table of Contents (cont.)

To jump to a particular section click on the section title.

| | |
|---|-----------|
| 12. Replacing Auto-belay Cables | 57 |
| 12.1. Mobile Wall Air Pressure Release | 57 |
| 12.2. Remove The Auto-belay Box Covers | 58 |
| 12.3. Remove The Rear Pin From The Pulley Bracket | 59 |
| 12.4. Remove The Internal Cable Mounting Bolt | 59 |
| 12.5. Remove The Cable | 60 |
| 12.6. Safety Inspection Of Internal Components | 60 |
| 12.7. Install New Cable Assembly | 62 |
| 12.8. Attach Marine Eye to Auto-belay Box | 63 |
| 12.9. Replace The Rear Pin On The Pulley Bracket | 64 |
| 12.10. Re-Attach Auto-belay Covers | 65 |
| 12.11. Cable Replacement Completion | 65 |
| 12.12. Re-Pressurize The Auto-belay Air/Oil Tank | 67 |
| 12.13. Auto-belay Operational Safety Inspection | 68 |
| 13. Cleaning And Other Special Care | 69 |
| 13.1. Protection From The Elements | 69 |
| 14. Quick Checklists And Log | 69 |
| 14.1. Per-Use Maintenance Checklist | 69 |
| 14.2. Periodic Maintenance Checklist | 70 |
| 14.3. Maintenance Log | 72 |
| 15. Safe Towing Tips | 73 |
| 16. Specifications | 74 |
| 16.1. Five-Climber Specifications | 74 |
| 16.2. Four-Climber Specifications | 75 |
| 16.3. Three-Climber Specifications | 76 |
| 16.4. Steel Framing and Weld Specifications | 77 |
| 16.5. Mobile Wall Lift Pump Specifications | 77 |
| 16.6. Auto-belay BELAY IN THE BOX™ Specifications | 77 |
| 17. Wiring Diagrams | 78 |
| 18. Battery Maintenance | 80 |
| 18.1. Marine Deep Cycle Battery Required | 81 |
| 18.2. Battery Operation | 82 |
| 18.3. Battery Charging | 83 |
| 18.4. What is and Why Use a “Smart Charger” | 83 |

Table of Contents (cont.)

To jump to a particular section click on the section title.

| | |
|------------------------------------|-----------|
| 19. Limited Warranty | 84 |
| 19.1. Warranty Claim | 85 |
| 20. Replacement Parts | 86 |
| 21. Technical Support | 86 |
| Warranty Claim Form | 87 |

Version Update Information

- 7.01 10/14/13
 - Added MW5 35 foot tall jack set up, turn buckles that are applied during towing and auto-belay pressure (75-85PSI) on mobile wall.
- 7.01 02/10/11
 - Added MW3 Specifications Table.
- 7.0 02/10/11
 - Combined obsolete products manual version 6 into this manual. All mobile climbing wall products are now supported by this manual.
- 2.0 07/30/09
 - Added Two-Climber, Three-Climber and Four-Climber clarifications where required.
 - Updated cable replacement section.
 - Added battery maintenance section.
 - Added Stabilizer Cable setup section.
- 1.1 08/14/08
 - Updated Specifications.
 - Reformatted Table Of Contents and added page numbers.
- 1.0 07/13/08
 - Original

1. Safety first! Read Before Proceeding



CAUTION: This is a safety alert symbol. It is used to alert you of potential personal safety hazards. Please read all safety messages that follow this symbol to avoid injury or death.

Always make safety your number one priority when setting up, operating, and taking down your mobile climbing wall.

1.1. Safety Rules



CAUTION: For your safety, read and follow all safety rules and safety instructions in this Owner's Manual before operating your mobile climbing wall.



CAUTION: DO NOT set up or operate the mobile climbing wall near overhead electrical lines, roof eaves, trees, or other overhead obstructions or hazards.

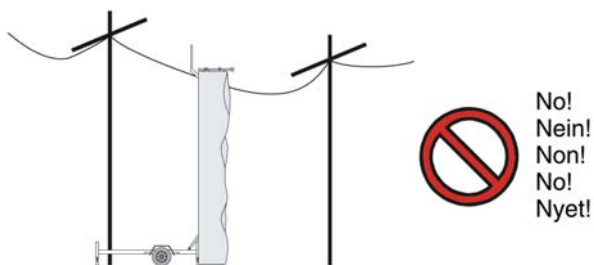

CAUTION: DO NOT set up or operate the mobile climbing wall in windy conditions where wind gusts exceed 30 MPH. Should wind gusts appear after setting up the mobile climbing wall, stop operating the mobile climbing wall and lower the mobile climbing wall immediately and safely.

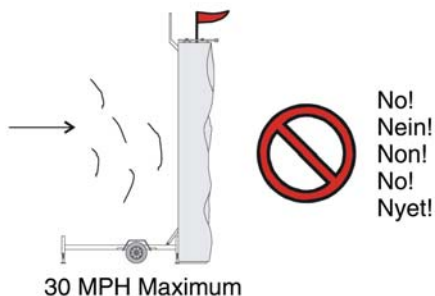



CAUTION: DO NOT set up the mobile climbing wall on uneven and/or non-level surfaces. The maximum slope allowed for setup and operation of the mobile wall is 3%. Within this 3% maximum slope, you can further level the wall with shims if necessary.



CAUTION: Set up the mobile climbing wall only on firm, hard packed, surfaces such as concrete, pavement, hard packed dirt, etc. **DO NOT** set up the wall on soft ground, sand or other unstable surfaces.

Extend the jacks down onto firm, hard packed, surfaces only. **DO NOT** use blocks under the jacks. **DO NOT** lower the jacks onto soft ground, sand or other unstable surfaces.



CAUTION: Although it is possible to set up the wall by a single operator, Extreme Engineering highly recommends a second operator to help with setup. This second operator can look for and warn of potential issues or hazards that may not be seen by one operator.



CAUTION: Keep the area clear of people, cars, etc. during setup. **DO NOT** walk under nor allow anyone to walk under the forward portion of the mobile climbing wall while it is being raised up to the operating position or being lowered down to the travel position.



CAUTION: DO NOT allow anyone to climb anywhere on the mobile wall other than the climbing surface. The climbing surface is where the handholds are installed and the Auto-belay cables retract up and extend down during operation.



CAUTION: DO NOT climb onto, sit or stand on the top of wall above the climbing surface.



No!
Nein!
Non!
No!
Nyet!



CAUTION: DO NOT free climb on the mobile climbing wall. All climbers must wear an approved climbing harness and be securely fastened to the Auto-belay cable with an approved carabiner between the cable swivel and the climbing harness loop at the front of the harness' waist belt.



CAUTION: Inspect the mobile climbing wall before each day's use.

The Maintenance Section of this User's Guide includes comprehensive details for making a complete inspection. Read that section carefully.

If you find any problems during the inspection which you cannot resolve, DO NOT operate the wall until the problem is corrected.

Visit Extreme Engineering's technical support web site at www.extremeengineering.com or contact Extreme Engineering's Technical Support at 916-663-1560 for help in correcting any problems.

2. Pre-Travel Checklist



CAUTION: For your safety, read all instructions before towing the mobile climbing wall.

2.1. Tow Vehicle Safety Check

- ✓ Check the air pressure in all tires including spare tire. Check for sufficient tread depths and tire damage on all tires.
- ✓ Check fuel and oil levels.
- ✓ Check dash gauges and warning lights with key on without engine running and with engine running.
- ✓ Check that all promotional items, lights, displays are secure and travel ready.
- ✓ Check the towing hitch and towing ball for proper attachment and tightness on towing vehicle per towing hitch manufacturer's specifications
- ✓ Check towing ball for proper size (2 5/16") and for abnormal wear.
- ✓ Ensure the weight limits of the tow vehicle's towing hitch is greater than the total load weight and tongue weight of the mobile wall.
- ✓ Ensure the towing capacity of the tow vehicle is greater than the weight of the mobile wall.

2.2. Mobile Wall Safety Check

- ✓ Check towing coupler mounting bolts for proper tightness.
- ✓ Check coupler for damage or unusual wear.
- ✓ Check tow tongue mounting bolts for proper tightness.
- ✓ Check travel lockdown pin is in place for towing.
- ✓ Check all tires (including spare tire if equipped) for proper air pressure.
- ✓ Check tires for legal tread wear depth.
- ✓ Check wheel lug nuts for proper tightness.
- ✓ Check mobile wall lift pump for proper oil level.
- ✓ Check for oil leaks from all hydraulic hoses and fittings from the lift pump to the hydraulic lift rams. Note: There may be oil residue found at the fill cap area of the lift pump oil reservoir tank. The fill cap is a breather cap and may allow a small amount of oil to escape from the tank during travel.
- ✓ Check for grease in the main hinge pins where the upper tower attaches to the lower trailer base at the rear.
- ✓ Check all Auto-belays for proper air pressure reading on all pressure gauges.
- ✓ Check all Auto-belays for unusual oil leakage. It is normal to find a small amount of oil residue on the Auto-belay hydraulic cylinders around the breather cap attached to the bottom of each Auto-belay cylinder.
- ✓ Check oil level in the air/oil Auto-belay tank on each Auto-belay for proper fill level.
- ✓ Check the lift pump battery for sufficient level of charge.
- ✓ Do a walking inspection of the trailer, and wall surface. Check for broken or loose handholds.
- ✓ Look for and remove any debris attached to the under body of the trailer.
- ✓ Check that the Auto-belay cables are secure and travel ready.
- ✓ Check that the carabiners are present and attached.
- ✓ Check that the trailer position is horizontal and level for travel.
- ✓ Remove wheel blocks for departure.

3. Prepare For Towing



CAUTION: For your safety, read all instructions before attaching the mobile climbing wall to the tow vehicle.

Extreme Engineering recommends a solid Tow Vehicle Hitch Receiver for towing the mobile wall. Ensure the solid receiver is properly inserted and attached per the towing hitch manufacturer's specifications and requirements. Check the towing hitch and towing ball for proper attachment and tightness on the towing vehicle per towing hitch manufacturer's specifications.

Ensure vehicle towing capacity and the towing hitch limits are greater than the total weight and tongue weight of the mobile wall.

Check towing ball for proper size (2-5/16") and for abnormal wear.



CAUTION: DO NOT tow the wall without the proper size towing ball. The ball must be a 2 5/16" diameter ball. A ball smaller than this can allow the trailer to unhitch even with the coupler locking latch and safety pin in place.

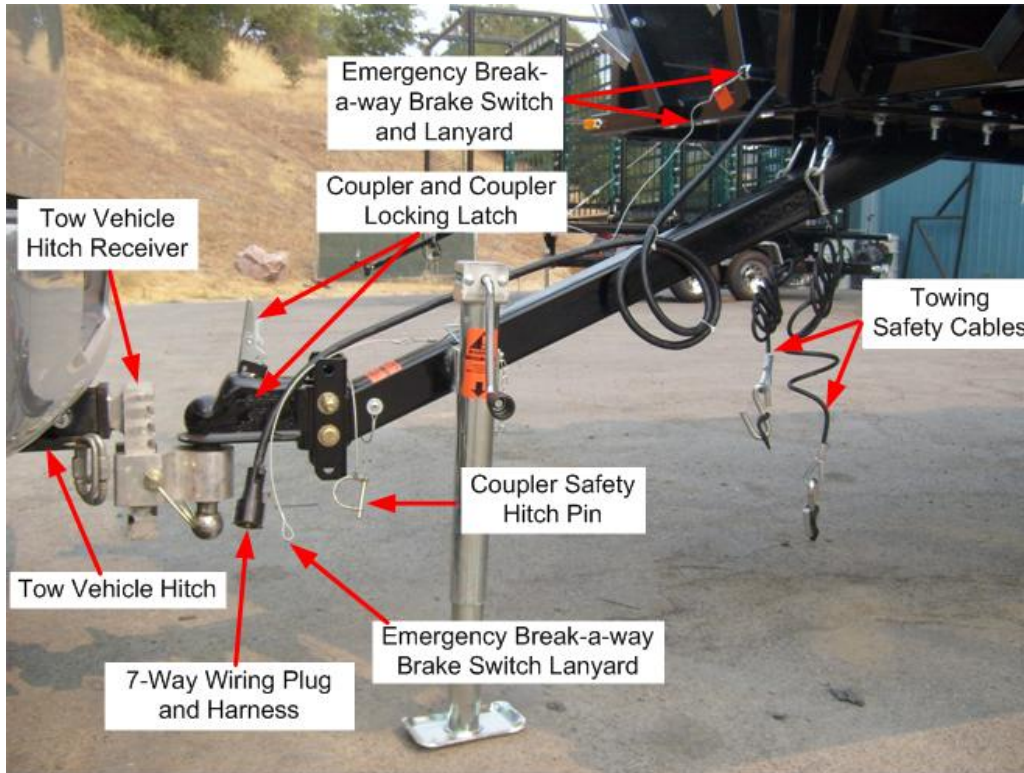

Mobile Wall and Tow Vehicle Towing Components

Note: MW2 Climber contains the same towing components with the following exceptions:

- There is no Emergency Break-a-way Switch and associated Lanyard.
- A 4-way flat connector and wiring harness is used instead of the 7-way harness.

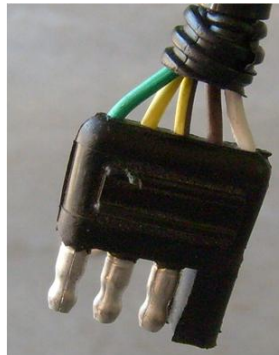

3.1. Attach Mobile Wall To Tow Vehicle

Back the tow vehicle into position so that its towing ball is positioned under the mobile climbing wall's trailer tongue. If you have a second operator, have him or her stand by the trailer to guide you into position. Position the tow vehicle's hitch as close as possible to the tongue of the trailer with the trailer coupler as close to directly above the towing ball as possible. Position the vehicle to minimize having to manually move the trailer into place.



CAUTION: Avoid having to manually position the trailer! If you must, do so only for the last few inches. **DO NOT** attempt to pull the trailer by hand, as this could result in serious injury.

Lower the coupler down onto the tow ball once the tow vehicle's tow ball is properly aligned with the coupler. Using the front jack mounted to the tongue, turn the jack handle counter clockwise until the coupler is fully engaged over the tow ball. Continue to turn the jack handle until the foot of the jack is clear of the ground and can be rotated 90 degrees to its travel position.

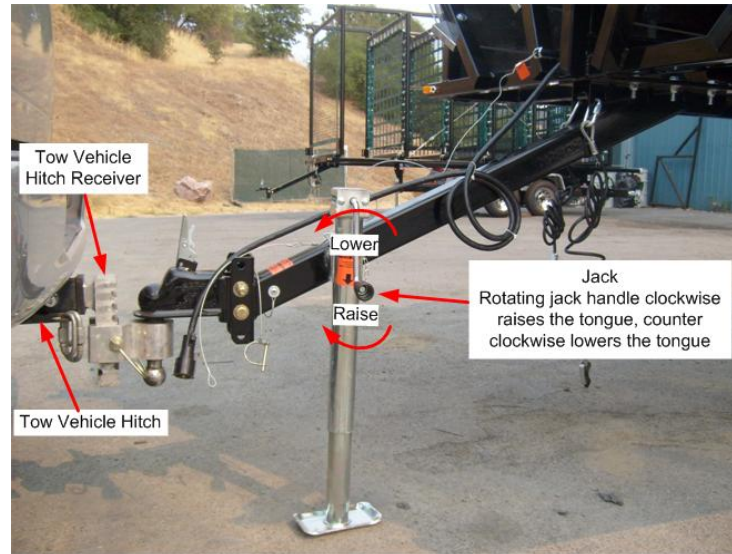

Lower the Coupler Latch Handle to the fully down position. **Ensure the Latch Handle Safety Lock inserts into its locking slot** on the coupler body underneath the latch handle. If the latch is in its proper position, you should not be able to lift the latch handle without first releasing the latch handle safety lock lever.



CAUTION: **DO NOT** tow the mobile wall without the latch handle in the locked position.

Locate the Safety Hitch Pin through the hole on the side of the coupler where the coupler latch handle mounts to the coupler body. **Slide the Safety Hitch Pin Clip over the pin** of the safety hitch pin to prevent the coupler latch handle from being accidentally released.

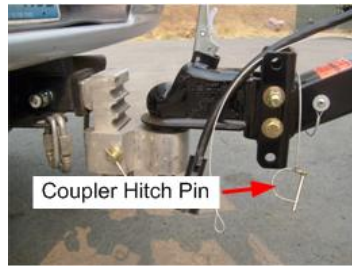

Coupler Hitch Pin attached to towing tongue with lanyard.



Coupler Hitch Pin location for towing.



Slide the Coupler Hitch Pin Clip over the end of the pin to lock in place.



Proper installation of Coupler Hitch Pin and Hitch Pin Clip set for towing.



CAUTION: DO NOT tow the mobile wall without the Coupler Hitch Pin properly set in place on the coupler latch handle.

Attach the two Towing Safety Cables to the tow vehicle's hitch.



Left Side Safety Cable



Right Side Safety Cable



CAUTION: DO NOT tow the mobile wall without the safety towing cables properly attached to the towing vehicle.

Attach the Electrical Plug from the mobile wall to the towing vehicle. The Two-Climber model uses the 4-way flat plug, all other models use the 7-way round RV plug (shown in the example below). Ensure the plug is fully inserted into the tow vehicle's electrical socket. Ensure the socket cover safety catch on the 7-way style is firmly in place down over the rear of the plug to prevent the plug from falling out during travel.



Electrical Towing Plug properly inserted into tow vehicle socket with socket cover safety catch down over trailer plug



CAUTION: DO NOT tow the mobile wall without the electrical plug attached to the towing vehicle.

Attach the Emergency Brake Break-a-way Lanyard to the tow vehicle. This is not applicable for the Two-Climber. The lanyard must be attached to the tow vehicle, not the towing safety cable. Ensure the emergency brake break-a-way switch pull tab is fully inserted into the break-a-way switch.



Emergency Brake Break-A-Way Lanyard Attachment



Emergency Brake Break-A-Way Pull Tab



CAUTION: DO NOT tow the mobile wall without the emergency brake lanyard attached (not applicable on the Two-Climber model).

Verify operation of tow vehicle and mobile wall lights. The mobile wall tail lights and yellow side marker clearance lights should be on when the tow vehicle's parking light or headlights are on. The mobile wall brake lights operate when the tow vehicle's brake pedal is depressed. Both of the mobile wall brake lights will flash when the tow vehicle's 4-way emergency switch is turned on. The mobile wall left and right turn signals should operate with the respective left and right turn signals of the tow vehicle.



CAUTION: DO NOT tow the mobile wall without operational tail lights, brake lights and turn signal lights.

Perform a secondary visual inspection. Ensure all towing components are properly attached and/or connected prior to towing the mobile wall.

3.2. Pre-Travel Safety Inspection Details

Position all Jacks to the travel position.

For the front tow tongue jack, pull the jack pin out, rotate the jack 90 degrees and re-insert the jack pin to hold the jack in the horizontal travel position.

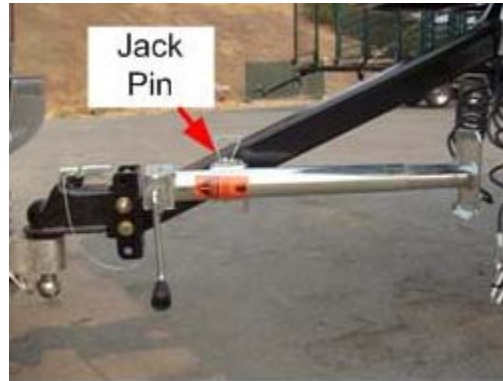

Front Jack

For the front trailer base jacks, pull the jack pin out, rotate the jack 90 degrees and reinsert the jack pin to hold the jack in the horizontal travel position.



For the Space Saver 1 style of trailer base only, the rear swing arm jacks are to be moved to the forward position for travel. Ensure the adjustable foot pad is raised to its highest level by removing the foot pad holding pin, lifting the foot pad upward until the pin can be inserted into the last hole to hold the foot pad up off of the ground at its highest position. Swing the arm toward the front of the trailer. Lift the holding pop pin up and push the swing arm completely in behind the fender and release the holding pop pin. Ensure the pop pin has fully engaged by pulling outward on the swing arm. If the pop pin is engaged, you will not be able to pull the swing arm outward away from behind the fender.

Space Saver 1 Style Rear Swing Arm Jack
Forward in Travel Position

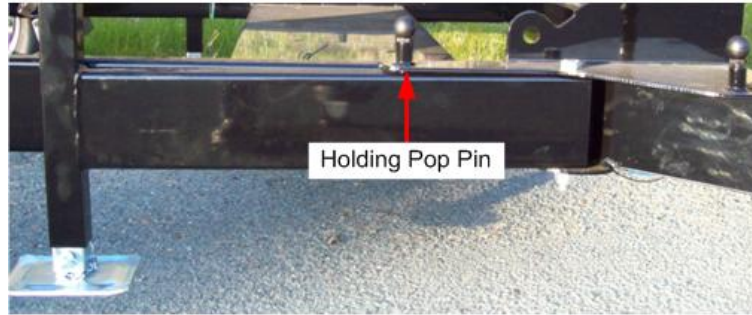

Space Saver 1 Style Rear Swing Arm Jack
Adjustable Foot Pad

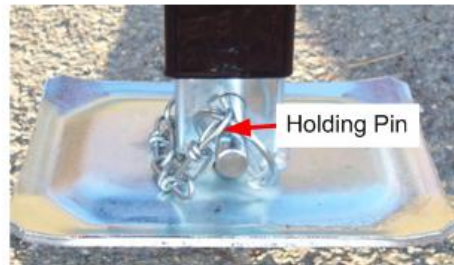

For all other NON Space Saver 1 style trailer bases, the rear jacks are to be placed on the inboard travel position spuds and located in the horizontal position. If your product does not have the inboard travel locating spuds to hold the jacks (e.g. MW2 mobile wall, Anniversary MW4 mobile wall), you can rotate the jacks to the horizontal position for travel. Or, you can remove them completely from the trailer and stow them elsewhere (e.g. tow vehicle, toolbox).

NON Space Saver 1 Style Rear Jack



Always remember to replace the jack pin fully through the jack and the holding spud when locating the jacks for travel.



CAUTION: DO NOT tow the mobile wall with any jack not in the travel position. Jacks can also be removed and stored in either the toolbox (optional equipment) on the mobile wall or in the tow vehicle during transport.

Mobile 35 foot tall climbing wall in towing position.

Setting outriggers into the towing position.



Ensure that the drop leg locks back into the jack.



Pull up the pop-pin to allow the outrigger to slide back towards the trailer.



Slide the outrigger towards the trailer until the pop-pin locks back into place.



Turn jack handle counter-clockwise until you no longer can raise the jack.



Repeat step on other outrigger if necessary.



Remove jacks and store safely away with unit.

Ensure the Tower Lockdown Pin is properly in place for towing.

Space Saver 1 Style Base

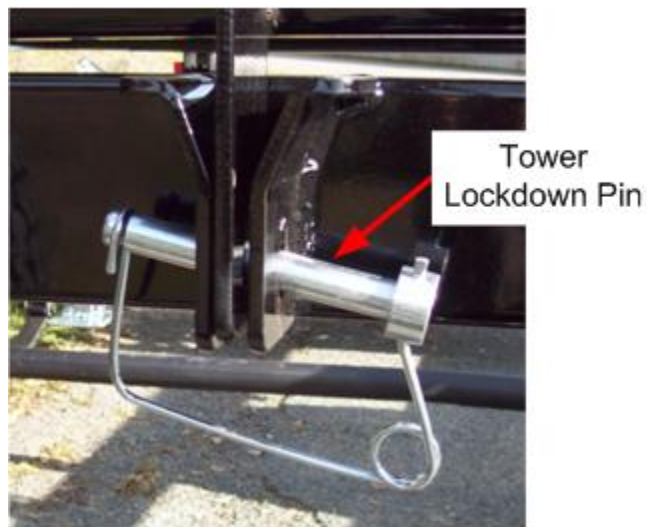

NON Space Saver 1 Style Base

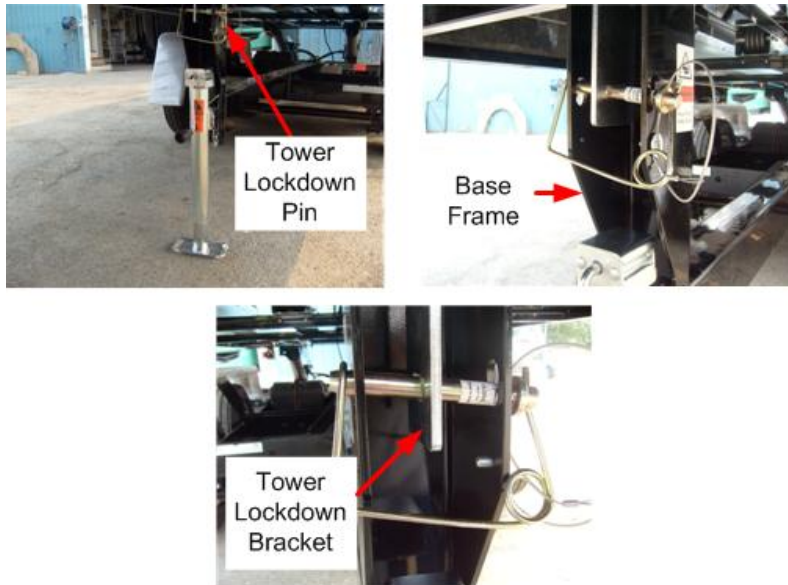

Ensure the Tower Lockdown Strap is properly in place (MW2 Mobile Wall). This model utilizes a ratchet strap and hook setup to hold the tower in place during transport. Place the hook over the lockdown loop of the tower located directly above the Tower Lockdown Strap on the tower frame. Tighten the strap with the ratchet strap latch handle securely. To tighten the strap, lift the handle up and then push the handle down to wind the strap onto the latch spool. Make sure to get a complete wrap of the strap around the latch spool. The strap must overlay itself to prevent it from loosening during transport. If the handle is fully in the down position, the locking lever will lock the handle in place to prevent the strap from loosening. If the handle will not raise, push on the latch handle to relieve the pressure on the locking lever and at the same time, press downward on the locking lever. This will release the locking lever and allow the handle to rotate upward.



Note: Periodic lubricating of the moving parts on the Tower Lockdown Strap mechanisms will keep the Tower Lockdown operating smoothly and freely. Use a light grade oil such as WD-40 or a dry Graphite Powder lubricant to lubricate the moving parts.



CAUTION: DO NOT tow the mobile wall without the tower lockdown pin, strap or chains properly positioned to lock the tower to the base during travel.

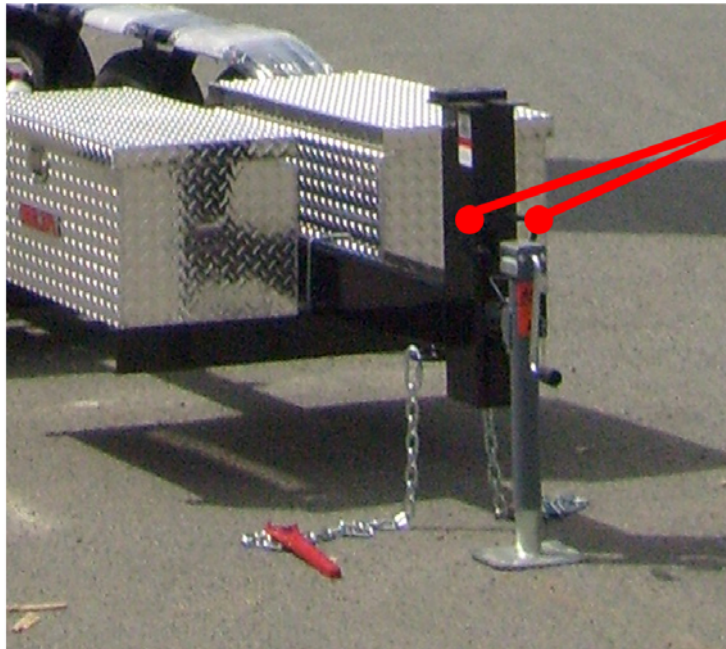

Turn buckle can be adjusted by twisting.

Ensure the Tower Lockdown turn-buckle is properly in place (MW5 35 Foot) This model utilizes a turn buckle “chain binder” to hold the tower in place during transport. Place the hooks over the lockdown loop of the tower located directly above the Tower Lockdown Strap on the tower frame. You will be applying the turn buckles from the frame of the climbing wall to the trailer. Tighten the turn buckles (there should be a set of 2). To tighten, twist the turn buckles.



CAUTION: DO NOT tow the mobile wall without the tower lockdown pin, strap or chains properly positioned to lock the tower to the base during travel.

Inspect all Wheel Lug Nuts, Tire Pressures and Tread Depths, Hub Dust Caps and Suspension.

The wheel lug nuts are to be torqued to 90 psi (pounds per square inch).

For factory supplied tires, the tire air pressure should be 50 psi with a cold tire. If you no longer have factory tires or exact factory replacement tires, use the recommended tire pressure imprinted on the side of the tire for proper inflation requirements. If you are not sure what the tire air pressure should be on your tires, any local tire shop can help determine what that pressure should be.

Check all tire tread depths for equal to or exceeding required tread depths. There are tire wear tread indicators in place on all tires in various areas around the circumference of the

tire between the tire treads. If these tire wear indicators are at the same height as the tread, the tires must be replaced.

Ensure the all hub dust caps are in place on all axles.

Check all mounting points of the suspension. Check to ensure the spring mounting shackles/bolts and u-bolts are in place and tight.

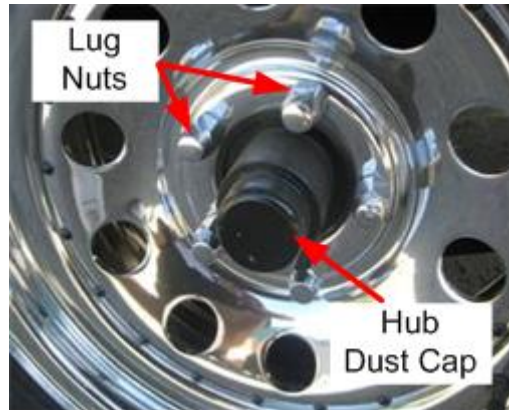

CAUTION: DO NOT tow the mobile wall with missing/loose lug nuts, improper tire air pressure, required minimum tire tread depth, missing hub dust caps or missing/loose spring mount components.

Inspect Fenders, Toolboxes and Spare Tire.

Check the toolbox (optional equipment) mounting points. Each toolbox is pop-riveted to the toolbox arms at each corner of the toolbox. The toolbox arms are mounted to the main base backbone frame with u-bolts. Ensure the u-bolts are tight and the pop-rivets are all in place.

The spare tire (optional equipment) is mounted on the main base backbone. The bracket is mounted with u-bolts and the tire is mounted to the bracket with two lug nuts. The spare may be mounted in different locations depending which optional equipment is installed.

For bolt on style fenders, check to ensure the mounting hardware is securely fastened to the fenders and the trailer base.

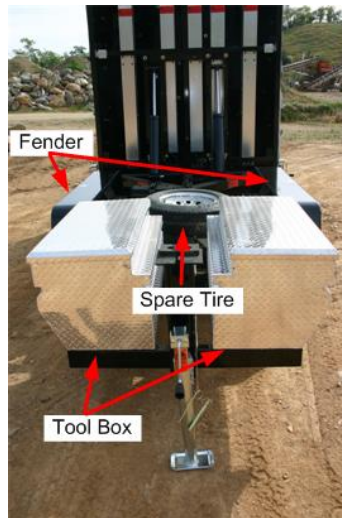

CAUTION: DO NOT tow the mobile wall with non-secured or improperly mounted fenders, toolboxes or spare tire.

Inspect Box and Hydraulic Pump/Hoses/Lift Rams

The battery box is mounted to the main trailer base pan with pop-rivets. Ensure all pop-rivets are securely in place.

The pump is mounted to the main trailer base pan with two bolts. The bolts are located underneath the base pan. Ensure the bolts are securely tightened in place.

The hydraulic lift rams are mounted to the base frame and the tower frame with clevis pins at each end. There is an external retaining ring on each outside end of the clevis pins holding the lift rams in place. For the Three-, Four- and Five-Climber model, there are two lift rams. For the Two-Climber model, there is a single lift ram.

Check for leaks at all hydraulic fittings and hose connections and lift rams.

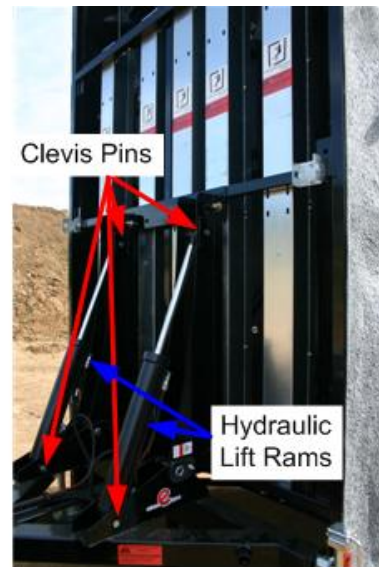
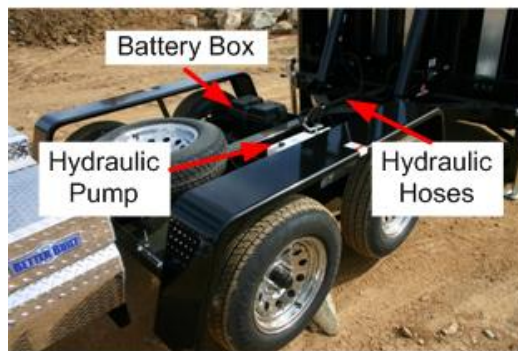

CAUTION: DO NOT tow the mobile wall with non-securely fastened battery box, hydraulic pump and lift rams. **DO NOT** operate the wall if there are leaks in the hydraulic hoses, fittings or lift rams.

Ensure the battery is sufficiently charged. Extreme Engineering recommends the battery be charged a minimum of every two to three lift cycles. The battery is a Group 27, Deep Cycle, Marine battery rated for boat trolling motors. Use of a vehicle battery will not work as a vehicle battery's intended use is far different from a marine battery's usage. To ensure continual success at raising and lowering the wall, Extreme Engineering recommends using a Smart Charger type of battery charger. This style of charger regulates the charge based upon what it reads from the battery as well as turning itself off when the battery is fully charged. **DO NOT** use a low amp trickle charger that does not turn off on its own. **DO NOT** leave the battery on charge for extended days as this will significantly shorten the life of the battery.

Insure the Hydraulic Lift Pump has sufficient oil. Maximum oil fill is when the oil in the tank is at the 2/3 level when wall is down. Never let the oil drop below the 1/4 level on the tank when the wall is in the fully upright position. When adding oil, use Dextron III Automatic Transmission Fluid.



 **CAUTION: DO NOT** operate the mobile wall with an insufficient oil level in the reservoir tank.

Inspect Tower to Base Lift Arm Mounting Bolts (NON SS1 Style Trailer). The upper tower frame is mounted to the lower base lift arms with a bolt at each end of each lift arm using Grade 8 bolts, washers and nylock nuts. Ensure there are no missing bolts and the bolts are securely fastened. If a bolt, washer or nylock nut requires replacing, it must have a Grade 8 rating. For the Two-Climber model, there is only one set of lift arms.

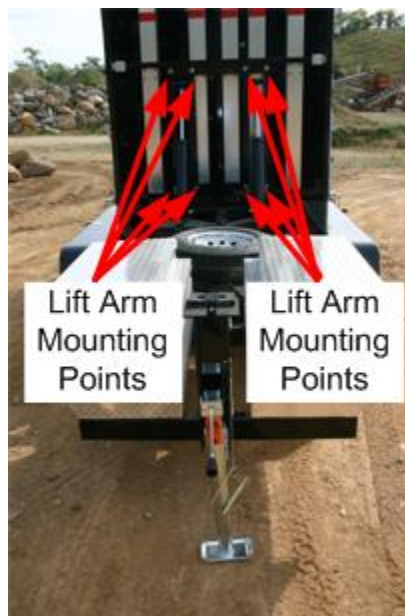

 **CAUTION: DO NOT** tow or operate the mobile wall with loose or missing lift arm mounting bolts, washers and/or nylock nuts.

Periodic greasing of Lift Ram and Base Hinge Pin zerk fittings. Using a grease gun, apply grease to both fittings of each lift ram and the fitting on each main hinge pin fitting. The fittings should be greased on a monthly basis. Apply grease until you can see new grease extruding from either side of the tubes which the zerk fittings are attached to.

SS1 Style Trailer Base

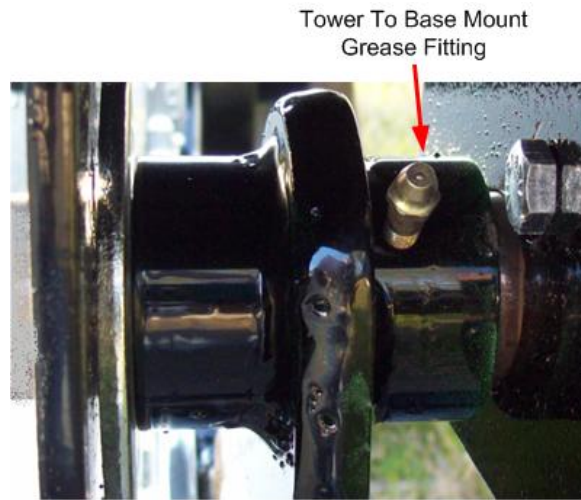

NON SS1 Style Trailer Base



Upper Ram Grease Fitting



Lower Ram Grease Fitting

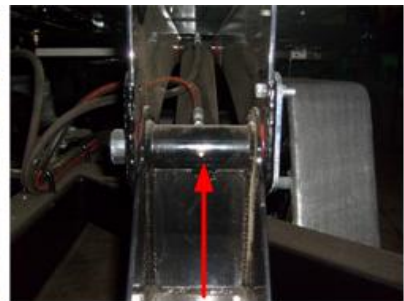

Base Hinge Grease Fitting

Verify all Auto-belays have the proper air pressure. The pressure should be between 60 and 65 psi (pounds per square inch) with the cables extended and attached to the eye-bolts at the bottom of the climbing surface. Air pressure is added by removing the plastic fill valve cap and pressurizing with an air pump using a standard automotive size air chuck. To reduce air pressure, first raise the wall using the pump controller three to four inches up off of the front tower rest. Remember to remove the tower lockdown pin prior to raising the wall. Raising the wall these few inches will prevent oil from spewing out while releasing air pressure. Remove the fill valve cap. Using any small blunt object, such as a screw driver, press the small tip in the center of the fill valve slowly until pressure begins to be released. Be careful that you don't bend the tip that releases the air during this procedure. There may be a very small amount of oil mist expelled during this procedure even with the front of the wall raised.

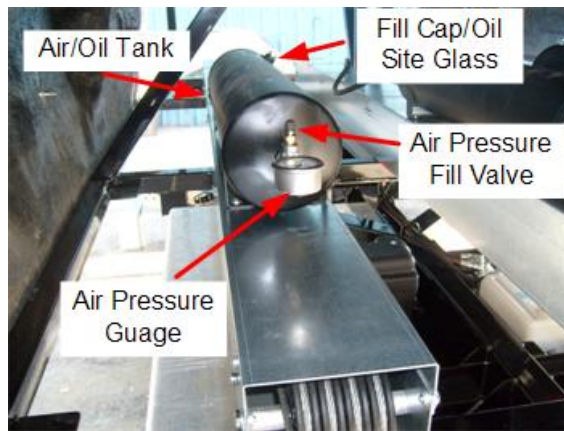

CAUTION: DO NOT operate the mobile wall without the proper air pressure in the Auto-belays.

Verify all Auto-belays are securely fastened to the tower frame. Verify all Auto-belay bolts attaching the Auto-belay box to the tower frame are not missing and are not loose. There are four bolts that attach the Auto-belay to the tower frame, two bolts at each end.

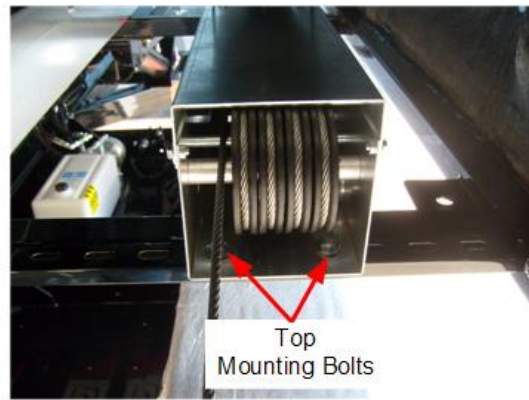
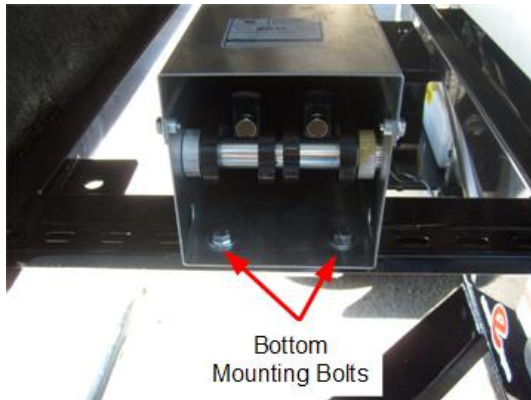

CAUTION: DO NOT tow or operate the mobile wall with loose or missing mounting bolts, washers or nylock nuts.

Inspect all Auto-belay Davit Pulleys for abnormal wear, ease of rotation and are securely fastened to the tower davit arms. There are two davit pulleys on each davit arm at the top of the mobile wall tower. Verify all bolts attaching the davit pulleys are securely fastened and the davit shields cannot be moved by hand. To verify ease of pulley rotation, pull on the cable before the davit pulley causing enough slack to release the pressure. Rotate the pulley to ensure it rotates freely and smoothly. If not, the davit pulley needs to be replaced. Inspect pulleys for abnormal wear or breakage. If breakage or cracking is found, replace the pulley. Should the inspection find abnormal wear, further inspection should be performed to determine the cause and appropriate corrective actions taken.

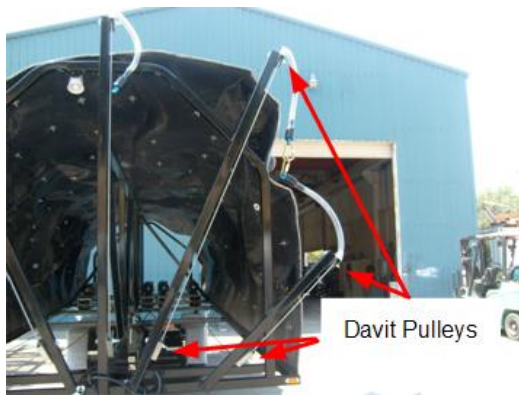

CAUTION: DO NOT operate the mobile wall with loose, damaged or worn davit pulleys.

Inspect the Auto-belay cables, swivels and carabiners for damage.

Ensure the Auto-belay cable twisted strands are tightly twisted with no bird-caging. Bird-caging is where all of the individual strands of the cable are untwisting and separating from each other. Ensure there are no broken strands or other damage found anywhere on the cable. If any of these conditions are found, the cable must be replaced prior to use.

Inspect all cable swivels for abnormal wear or damage. If found, cable assembly must be replaced.

Inspect all carabiners for abnormal wear or damage and the triple locking action of the carabiner clasp is operating properly. If wear abnormal wear is found, replace the carabiner as soon as possible. If the locking action is not working properly, **DO NOT** use the carabiner. It must be replaced.



CAUTION: DO NOT operate the mobile wall with damaged cables, swivels or carabiners. **DO NOT** use cables, swivels or carabiners with excessive wear. **DO NOT** use any carabiner where the triple action locking mechanism of the clasp does not operate properly on its own without help.

Attach Auto-belay cables for travel. Allow the Auto-belay cables to retract fully to the top of the wall. To prevent damage to the cables, mobile wall, passing vehicles, or possible injury to pedestrians during travel, connect the two outside cables on each side of the wall together using the carabiners.





CAUTION: DO NOT tow the mobile wall with without securing the two outside Auto-belay cables.

4. Mobile climbing wall Setup



CAUTION: For your safety, read all instructions before pulling the tow vehicle away from the mobile climbing wall. Prior to positioning the mobile climbing wall, read and follow the safety instructions found at the beginning of this manual.

4.1. Position The Mobile Climbing Wall

Using the tow vehicle, **position the mobile wall** in the location where it will be operated. Ensure there is an adequate operational area entirely around the mobile wall and overhead for raising, operating and lowering the wall. Ensure that you are setting up the wall on level and firm surfaces.



CAUTION: Never place the wall in an area to be operated in close proximity to overhead obstacles, such as power lines, trees or building roof eaves, that may interfere with operation of the mobile wall. **Never** place the wall in close proximity of overhead electrical power lines, of any type, at any time.



CAUTION: DO NOT set up the wall on soft ground, sand or other unstable surfaces. **DO NOT** use blocks under the jacks. **DO NOT** lower the jacks onto soft ground, sand or other unstable surfaces.

Block the wheels of the trailer with blocks or wheel chocks to keep the wall from moving when unhooked from the tow vehicle.

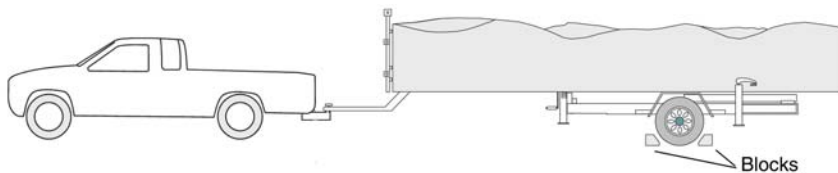

4.2. Unhitch Tow Vehicle

Reset the front jack for removal of the climbing wall from the tow vehicle. Pull the pin holding the tongue jack in the horizontal travel position. Rotate the jack 90 degrees to the vertical position with the foot of the jack near the ground. Replace the pin holding the jack to the tongue.

Unhook all towing components. Disconnect the Electrical Plug, the Emergency Brake Break-a-way Lanyard (if applicable), the Towing Safety Cables and the Safety Hitch Pin.

Release the Coupler Latch Handle. Remove the coupler safety hitch pin from the coupler latch handle. Pull up on the Latch Handle Safety Lock and then lift the Coupler Latch Handle 90 degrees to the fully vertical position.



Raise the coupler up off of the tow vehicle hitch ball. This is accomplished by rotating the jack handle on the jack counter clockwise. Rotate the jack handle until the coupler is completely up off of the ball. Ensure there is enough clearance between the ball and the bottom of the coupler to allow the tow vehicle to be driven away without catching the coupler.

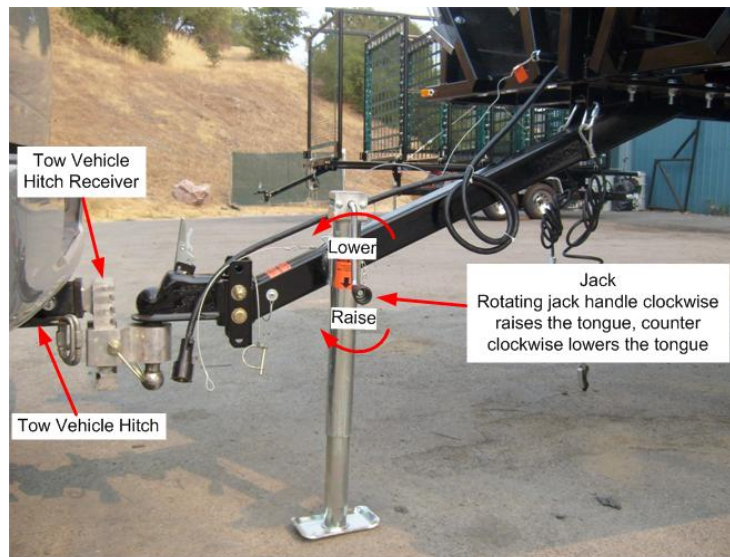

Park the tow vehicle. Move the vehicle away from the operational area.

4.3. Prepare The Wall For Raising



CAUTION: For your safety, read all instructions before setting up the mobile climbing wall for operation.

Move Jacks from their travel position to their operational position.

Space Saver 1 Style Trailer – Rotate one front side jack to its vertical operational position. Ensure the jack pin is fully inserted all the way through the jack and jack holding spud. Raise the front of the wall using this jack until the tongue jack raises up off of the ground. Move the tongue jack back to the opposite front side of the trailer base. Attach the jack vertically to the jack holding spud with the jack pin fully inserted all the way through the jack and jack holding spud. Raise the jack until it is also firmly on the ground and at an equal height that causes the front of the trailer base to be level horizontally.



Pull the pop pin up holding the rear swing arm jacks in their forward travel position and pull out on the jack swing arm. Rotate the jack swing arm all the way to the full rearward position. Lift the rear pop pin up and push the swing arm fully against its rearward position. Release the pop pin and ensure it has engaged the swing arm by pulling outward on the swing arm jack. The jack should stay in place, not able to swing out from its locked operational position.

Space Saver 1 Style Rear Swing Arm Jack
Forward in Travel Position



Space Saver 1 Style Rear Swing Arm Jack
Rearward in Raising/Lowering Position



NON Space Saver 1 Style Trailer – Take one of the rear jacks and place it in the middle position at the tower rest below the lockdown pin. Always place the jack pin all the way through the jack and the jack holding spud. Raise the jack by rotating the handle counter clockwise until the tongue jack lifts up off the ground. Remove the tongue jack by pulling out the jack pin and move this jack to the vacant rear side jack operational position.



Move the remaining rear jack from its travel position to the operational position.



Rear Jack Travel Position



Rear Jack Operational Position

For the MW2 Two-Climber model, place one of the rear jacks on the jack mounting spud located two feet in front of the base pan which holds the hydraulic lift pump. Always place the jack pin all the way through the jack and the jack mounting spud prior to raising or lowering a jack. Raise this jack by rotating the handle clockwise until the tongue jack lifts up off the ground. Move the tongue jack back to the vacant rear side jack operational position.

For MW5 35 foot mobile wall model.

Setting outriggers into the operating position.



Pull up the pop-pin to allow the outrigger to slide back towards the trailer.



Slide the outrigger out from the trailer until the pop-pin locks back into place.



Turn jack handle clockwise until the jack firmly rests on the ground. Make sure there is no debris under the foot of the jack. Repeat step on other outrigger.



NON Space Saver 1 Style Trailer

Remove the Tower Lockdown Pin, Strap or Chains. Release the spring clip from the pin and remove the lockdown pin fully from it's travel location. The lockdown pin can hang from it's lanyard while not in use.

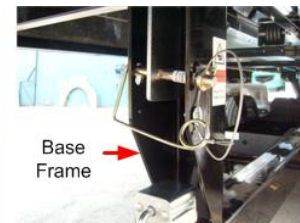
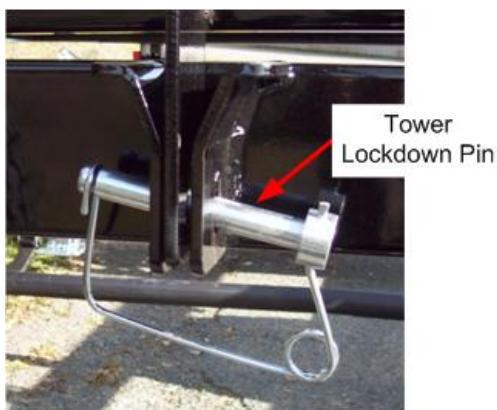

The MW2 Two Climber model utilizes a lock down ratchet strap. When the handle is in the fully down position, the locking lever will lock the handle in place to prevent the strap from loosening. To release the strap, push down on the latch handle to relieve the pressure on the locking lever and at the same time, press downward on the locking lever. This will release the locking lever and allow the handle to rotate upward and allow the strap to loosen. Remove the strap hook from the lockdown loop of the tower frame.





WARNING: Severe damage will occur if you attempt to raise the wall without removing the lockdown pin, strap or chains.

The MW5 35' mobile wall uses turn buckles. Un-twist, to loosen, the turn buckles and remove them from the trailer and climbing wall frame before raising.



Turn buckle can be adjusted by twisting.



WARNING: Severe damage will occur if you attempt to raise the wall without removing the lockdown pin, strap or chains.

4.4. Stabilizer Cable Setup

There are two different stabilizer cable configurations. Some models of climbing walls do not require stabilizer cables. If your model came with stabilizer cables, reference the proper configuration pictures below to attach the components and to attach the cables to the trailer and tower frame. Ensure you attach the stabilizer cables prior to raising the wall into its operational position.

NON Space Saver 1 Style

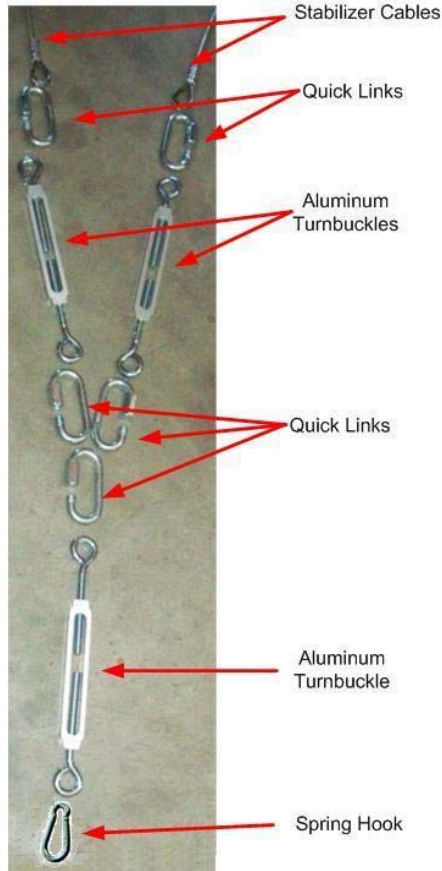

Space Saver 1 Style

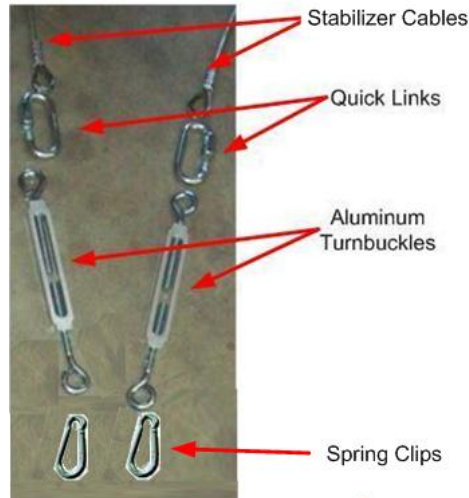

The top end of the stabilizer cables for all models have spring hooks attached to each cable eye.

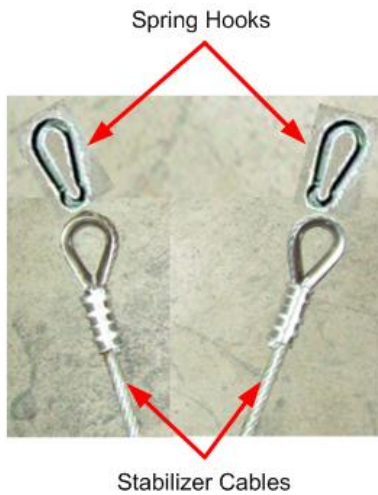

The two top Spring Hooks on the stabilizer cables are attached to the stabilizer cable loops welded underneath the top of the tower frame, one cable on each side of the tower.



The single bottom Spring Hook of the stabilizer cables is either attached to the eye bolt located behind the tower rest (NON Space Saver 1 style) or to the stabilizer cable loops welded to the base frame (Space Saver 1 style).

NON Space Saver 1 Style

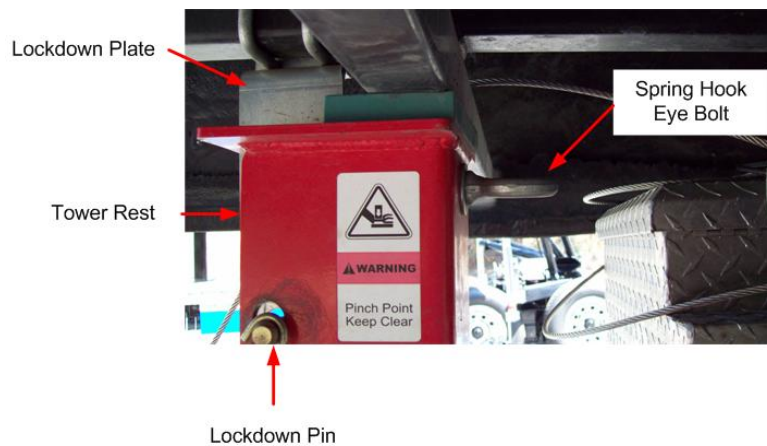

Space Saver 1 style setup utilizes the welded-on loops at the front of the trailer base near each front side jack location.

Space Saver 1 Style

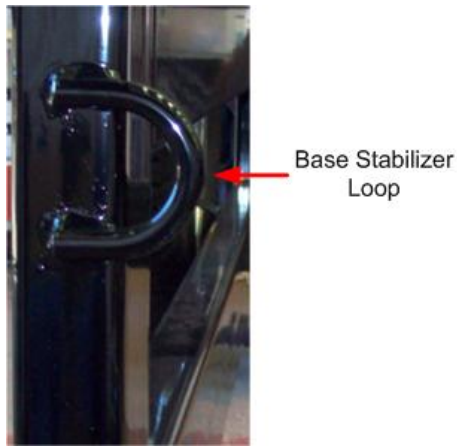

All stabilizer cables need only be snug once the wall has been fully raised. Turn the turn-buckle to tighten or loosen the cables until they are snug only. DO NOT over tighten the cables and then raise the wall as this will damage the stabilizer cable components or the attachment points on the base and/or tower frame.

4.5. Prepare The Auto-belays

Verify Auto-belays are ready for use. Check for and remove any debris in or around the Auto-belays, cables and davit pulleys that may have occurred during transport. Verify there is no oil leakage at all fittings, gauges, fill valves and hoses on the outside of the Auto-belay. Verify there is no excessive oil leakage from the breather caps located at the bottom of each of the hydraulic cylinders. The breather caps allow air to enter and exit the cylinders as they extend and retract with cable usage.

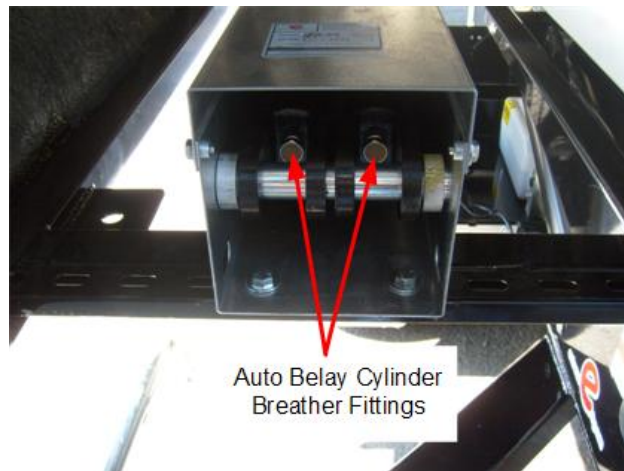

Note: There may be a small amount of oil weeping from the Auto-belay breather caps. Weeping is considered normal. Weeping is where there are traces of oil seen around the caps or the bottom of the Auto-belay box. There may be a drop or two of oil seen on the ground during use. Weeping is considered to be normal.

At no time should the Auto-belay exhibit a continuous dripping of oil from these caps or any where else on the Auto-belay. If there is more than the normal weeping of oil and you have to add 5 to 10 psi air pressure over the course of a month in conjunction with an oil loss,

this is considered excess leakage. Any Auto-belay cylinder that exhibits excess leakage must be replaced.



CAUTION: DO NOT operate any Auto-belay that demonstrates excessive oil leakage. The Auto-belay must be repaired prior to any use. If you are unsure whether an Auto-belay is leaking or weeping, contact Extreme Engineering Technical Support for help.

During travel, the Auto-belay cables are fully retracted, with the cable swivel and carabineer at the top of the wall. The outer cables on each side of the wall are attached together with their carabiners. Unhook the two outer carabiners to separate the cables. Extend the Auto-belay cables to the rear of the wall and attach them to the eye-bolts, approximately 3 feet from the bottom of the climbing surface, with the carabiners.

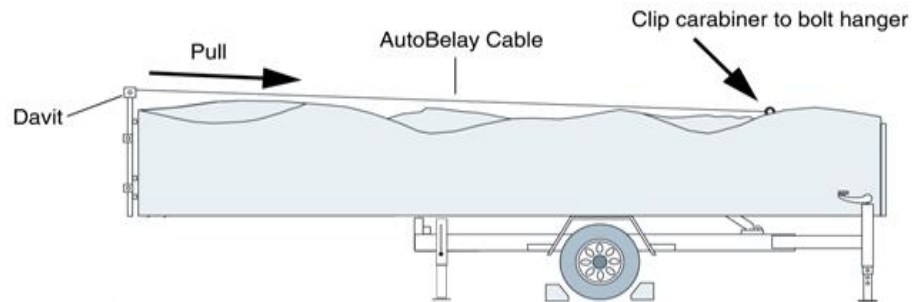

NOTE: Be sure to **lower the cables before raising the wall**. If you forget to attach the Auto-belay cables to the bolt hangers prior to raising the wall, you must lower the wall to retrieve the cables and then raise the wall after pulling out the cables and attaching them to the eye bolt hangers.



CAUTION: DO NOT free climb the wall at any time without wearing a climbing harness and an Auto-belay cable attached to the harness with a carabiner.

4.6. Raise The Wall



CAUTION: For your safety, read all instructions before raising the mobile climbing wall for operation.

Raise all tires of the mobile wall off the ground. Using the jacks, raise the mobile wall until the tires are approximately four inches off the ground. Rotating the jack handle clockwise raises the trailer, counter clockwise lowers the trailer. Ensure the wall is level from both the side view as well as the rear view. When the tires are off the ground four inches, push on one of the rear wheels of the trailer with your foot. This will cause the rear axle to drop down in most cases if it hasn't done so on its own during the raising of the wall. Should the axle drop down during actual climbing use, this action can scare or cause unnecessary concern by the climbers.

Attach the hydraulic lift pump controller. Insert the metal plug attached to the controller to the controller socket attached to the pan of the trailer base. The socket is found at the rear of the base on the left side trailer pan near the fender mounting bracket. Raise the protective cover of the socket and fully insert the controller plug.

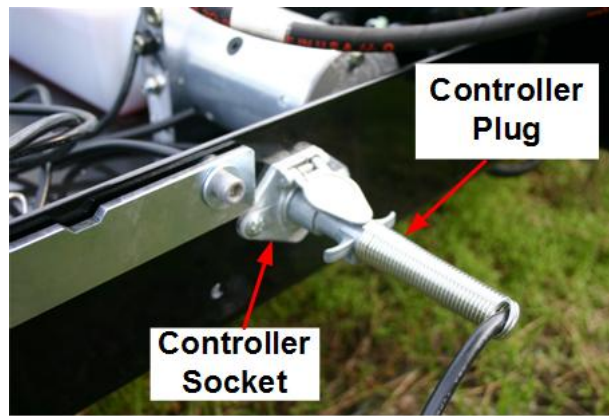

Raise the wall with the controller. Press up on the controller toggle switch to raise the wall. While the wall is raising, listen for any abnormal sounds. Watch the wall as it raises to ensure it continues to raise and is raising at its normal speed.

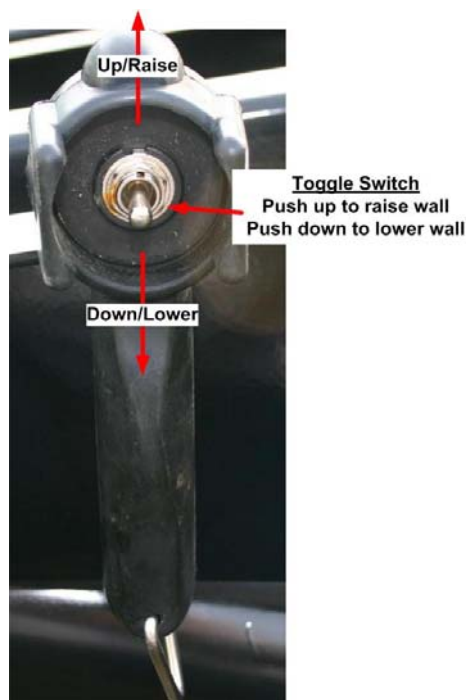

Raise the wall until it is fully upright in the vertical position. Watch the base frame of the climbing tower frame to ensure that it will clear the ground when approaching and completing its final vertical position. If the frame is not going to clear the ground, raise all three jacks evenly, a small amount at a time to prevent the wall from leaning too far to the left or right side. If it gets tilted to far with one jack, there is a possibility of the wall falling. Raise the jacks enough that the tower frame will clear the ground. Complete the lift cycle.

Raise the wall to the vertical position in one *continuous* motion. Try to avoid pressing the UP button multiple times during the raise cycle. **Do Not** continue to force the wall any further than it's complete vertical position. This can cause damage to the frame.

If the wall is raising slower than normal or the pump sounds like it is laboring to raise the wall, this could be a sign of a weak charge on the battery.

In an emergency, to raise the wall with a weak battery, the battery can be hooked up to the tow vehicle battery temporarily to complete the raise cycle with jumper cables. Once the wall has been raised successfully, remove the jumper cables from the and move the tow vehicle away from the operational area.

If the wall had to be raised with the help of the tow vehicle, it will also require help when lowering. The default operation of the pump is to raise the wall. When battery power drops below a sufficient level, the direction control module will not engage when the pump is running. The direction control module reverses the flow direction of the hydraulic oil and this causes the wall to lower. If the direction control module does not engage, the pump will only attempt to lift the wall further. It will not lower.

It is also possible that there is sufficient charge to raise the wall with the battery, but the raise operation drains the battery enough to where it won't lower due to the inability to engage the direction control module while the pump motor is running. In both of these cases, you will have to connect the tow vehicle battery to the wall battery to lower the wall.

Attaching the tow vehicle battery to jump the wall battery is the same as jumping another vehicle that won't start. Attach the positive jumper cable lead to the positive post on the mobile wall battery. Attach the negative lead to the negative post on the mobile wall battery. Make sure that the opposite ends of the negative and positive leads on the jumper cables Do Not touch each other or any portion of metal on either the mobile wall or the tow vehicle inadvertently. Attach the positive lead to the tow vehicle's positive battery post. Lastly, attach the remaining negative lead to a good solid metal ground point on the tow vehicle. Start the tow vehicle and then lower the wall using the controller. Carefully disconnect the leads by first disconnecting the negative cable from the vehicle ground point and the positive battery post. Remove the negative lead from the mobile wall battery and then remove the positive lead from the battery.

A good battery will provide from four to eight lift cycles before requiring charging. The number of lift cycles depends on the age of the battery and frequent charging of the battery. Extreme Engineering recommends starting each usage season with new battery. Having a secondary backup battery that is always fully charged is also a good preventative measure for low battery charge conditions that may occur during operation.

Remove the controller from the mobile wall. Once the wall has been fully raised into its operational position, remove the controller from the controller socket. Store the controller in a safe place that will guarantee it cannot be reattached and/or activated during the climbing event for the wall.

Lower the jacks as evenly as possible until the base of the tower sits firmly on the ground. Turn the jack handles counter clockwise to lower the wall until the base of the frame is firmly on the ground. Lower the base to the ground utilizing all three jack a small amount at a time to keep the wall as close to vertical as possible to prevent the mobile wall from possible tipping over onto its side.

Continue to leave the jack foot pads in firm contact with the ground as an additional stability measure. But, the weight of the tower should be held by the tower frame, not the jacks.

Push on the climbing panel both sideways and front to back. This operation will

ensure that the wall is settled completely down on its resting location. If the wall can be rocked by hand in either of the two directions, the wall will either need to be relocated to a more level surface, or, minimal shims can be used to stop the rocking. Shims, such as wooden building construction leveling shims (like those used to level and square a doorway) are acceptable.

NOTE: You can use shims to level the base of the wall, as long as they are of a sturdy, non-compressible material. If you have a gap of more than 1-1/2", the wall should be repositioned to a more level surface. Use a minimal number of shims. Make a final inspection of the shims when all other setup steps are completed, to ensure they are secure.

The wall should ideally be at exactly 90 degrees vertical, when viewed from the front/back view and left/right side to side view.

Space Saver 1 Rear Jacks Only – After the wall has been completely setup, you can adjust the placement of the rear swing arm jacks to move them out of the way for the side climbing runs. Raise the jack until you are able to move the jack forward. Lift up on the holding pop pin and swing the jack straight out perpendicular to the trailer base. Lower the jack in this position until the foot of the jack is firmly on the ground. Repeat this operation for the opposite side of the wall. Do not attempt to lift the wall up off the ground with the jacks in this position. To lower the wall, lower the jacks until the jack can be swung back to the raise/lower position. Lift the pop pin and push the swing arm completely to the rearward position. Release the pop pin and ensure the jack cannot be swung away from its position. Lower the jacks back down to the ground for lowering the wall.

4.7. Prime Before You Climb

PRIME BEFORE YOU CLIMB



CAUTION: Exercise every Auto-belay by strictly following these test procedures.

The following test procedures are performed on every Auto-belay as a part of the setup process prior to using the climbing wall or after performing maintenance on an Auto-belay.

When performing this test on a Mobile Climbing Wall, you must first raise the wall to its fully upright operating position. Follow your Mobile Climbing Wall Owner's Manual to properly prepare for and raise the Mobile Climbing Wall.

Test each Auto-belay operation by first priming the system before you climb. This "**Prime Before You Climb**" operation must be performed prior to the first climb of each day. This test procedure is required after replacing Auto-belay cables or replacing auto-belay parts prior to allowing anyone to climb to the top of the wall, including yourself. As a good measure of safety, you should periodically recheck the Auto-belay operation a couple of times throughout the day's operation of the wall.

Step 1: Disconnect the cable from the eye-bolt near the bottom of the climbing surface and fully extend the cable (pull the cable all the way out) until it stops. Holding onto the cable, allow the cable to retract back into the Auto-belay three to four feet and then fully extend

the cable again until it stops. Perform this action a minimum of four times. This action will purge any air that may have relocated from the air/oil reservoir tank into the hydraulic system of the Auto-belay.



CAUTION: If this step does not exhibit proper auto-belay operation, **DO NOT Proceed, DO NOT use the auto-belay. Contact Extreme Engineering for assistance.**

Step 2: Before you climb, put on a climbing harness and attach the cable to the harness with the carabiner. With your feet on the ground near the bottom of the wall, lean backwards and attempt a backward fall. If the Auto-belay is working properly, you will not be able to fall backwards. The Auto-belay should slowly lower you, resisting an unrestricted fall. If you are not safely lowered to the floor, repeat the pumping actions again.



CAUTION: If this step does not exhibit proper auto-belay operation, **DO NOT Proceed, DO NOT use the auto-belay. Contact Extreme Engineering for assistance.**

Step 3: Only if the previous step passed with proper Auto-belay operation can you proceed with this step. Make a short climb, **NO MORE THAN THREE FEET**, up off the ground. Release and ensure the Auto-belay provides the proper controlled and restricted descent back down to the ground. You should be lowered slowly down to the ground.



CAUTION: If this step does not exhibit proper auto-belay operation, **DO NOT Proceed, DO NOT use the auto-belay. Contact Extreme Engineering for assistance.**

Step 4: Only if the previous step passed with proper Auto-belay operation can you proceed with this step. Climb the wall up to the halfway point of the climbing wall panel surface, **NO MORE THAN HALF WAY**. Release and ensure the Auto-belay provides the proper controlled and restricted descent back down to the floor. You should be lowered slowly down to the ground. If not, go back to Step 1 and start all over again.



CAUTION: If this step does not exhibit proper auto-belay operation, **DO NOT Proceed, DO NOT use the auto-belay. Contact Extreme Engineering for assistance.**

Test Climb – Cable Retraction Verification

After the initial four steps of the Prime Before You Climb test is completed successfully, you are now ready for a complete climb test. While wearing a climbing harness attached to the auto-belay cable with a carabiner attached to the proper carabiner loop on the harness, climb to the top of the wall. The cable should retract, on its own, the entire climb to the top of the wall. Check that the cable retracts smoothly and retracts with you all the way to the top. Should the cable not retract completely to the top of the wall, stop climbing at the point the cable stops retracting. Carefully climb down the wall until the proper tension and restricted lowering is felt on the cable. If proper restricted extension of the cable is achieved, you can utilize the auto-belay to lower back down to the bottom. If not, you must climb down the wall using the handholds and not rely on the Auto-belay.

The most typical reason for a cable to not retract fully to the top of the wall is air pressure. Check the pressure in the gauge for the auto-belay. Proper pressure is between 60 and 65 psi with the cable extended to the bottom of the wall and hooked to the eye-bolt. Normal operation should return for the cable retraction if the problem was too low of air pressure.

If the cable does not retract fully and the air pressure is within specification, the Auto-belay is getting stuck from an obstruction or is binding and not operating properly. **DO NOT** use the Auto-belay until the cause of the obstruction or binding is located and resolved.



CAUTION: DO NOT use an Auto-belay that does not retract the cable completely to the top of the wall. Contact Extreme Engineering Technical Support assistance on troubleshooting.

Test Climb – Auto-belay Controlled Descent Verification

When descending back down the wall, ensure your descent is slow and controlled by the operation of the Auto-belay for the full decent to the ground. The descent is smooth without any drops, halts or jerky motions.

The descent from the top should be at the same rate of speed from the top to the bottom for the full run of the cable. If the air has not been fully purged from the system, there is a chance that the releasing from the top of the wall to lower back down to the ground will cause an unrestricted releasing of cable for a short distance before the auto-belay begins to belay properly. If the auto-belay exhibited proper restricted extension of the cable for the several short climbs prior to climbing to the top, the auto-belay should belay properly prior to the cable reaching the full length of travel to the bottom of the climbing wall. If the descent at the top of the wall is faster than normal, there is still air in the wrong location of the Auto-belay system. Air must be only in the reservoir tank along with the proper level of fill of automatic transmission fluid.

It is also possible to exhibit these same symptoms should the auto-belay develop an excessive leak and the fluid goes below the critical fill level. The auto-belay oil level from the factory is slightly above the half way point on the tank. The critical level is reached when the oil drops below the top of the glass in the site glass window. The site glass is three inches up from the bottom of the air/oil reservoir tank on one side and is either brass or nickel plated.



CAUTION: Any auto-belay that does not exhibit the same slow and controlled extending of cable for the full length from the top to bottom of the wall must be shut down immediately. **DO NOT** use the auto-belay until it can be inspected and the problem corrected. Contact Extreme Engineering Technical Support assistance on troubleshooting.



CAUTION: The air pressure in the Auto-belay system is what causes the cable to be retracted when releasing the cable or climbing the wall with the cable attached to the climbing harness. This restriction of movement provided by the air pressure is **NOT** enough for proper cable extension operation of the Auto-belay.

The oil in the system is what provides the proper restriction to control the speed of descent when a climber is being lowered to the ground by the Auto-belay. If there is air in the system when a person has climbed to the top of the wall and then releases to lower back down to the ground, the descent will NOT be slow and controlled. Personal injury may occur if the air has not been fully purged from the system.

If air is displaced from the air/oil tank into the hydraulic check valves at the hydraulic cylinders inside the Auto-belay box, there will not be the proper restriction of movement when the cable is pulled out of the Auto-belay. DO NOT CLIMB a wall with an Auto-belay that does not exhibit the proper restricted movement when extending the cable out of the Auto-belay for the complete length of travel from the top to bottom of the climbing wall surface. There is a very noticeable difference in resistance when extending the cable out with air in the check valves versus oil in the check valves. DO NOT CLIMB with an Auto-belay with air in the check valves.

5. Prepare For Operating The Wall

These final steps will make the mobile climbing wall ready for climbers.

It's a good idea to have a crowd control barrier around the mobile climbing wall. You might use stanchions to keep those waiting to climb out of the climbing area and to provide a place for climbers to line up while waiting.

We recommend having a 6 to 8 foot radius in front of the mobile climbing wall to keep people clear from climbers. This is what we call the "climbing zone" that can be used to harness, de-harness and allow the general public to climb in a safe area.

Set up a cashbox and table near the crowd control ropes at one side of the mobile climbing wall.

The cashbox and table should be adjacent to a "harness area," so one operator can both collect money and harness climbers. If you use tokens or tickets, the operator will still need to collect these. (See the Operating Techniques section below.)

Establish your method of entrance control. This includes how tickets are used, supervising the entrance point to the line, etc.

Make sure your operators are clear on your procedures.

Make sure you are in compliance with any applicable rules and regulations at the site or event.

You should have a plan established for handling contingencies like medical or other emergencies, even though these are unlikely to occur. Make sure every member of your crew knows this information.

6. Banner Setup

Always set up your banners prior to raising the wall.

If the banner kit was purchased with the wall, the holding brackets will have already been installed. If you are adding the banner kit at a later time than the original wall purchase, you will need to install the banner holding brackets. Once attached you can leave them permanently attached to the wall.

NON Space Saver 1 Style

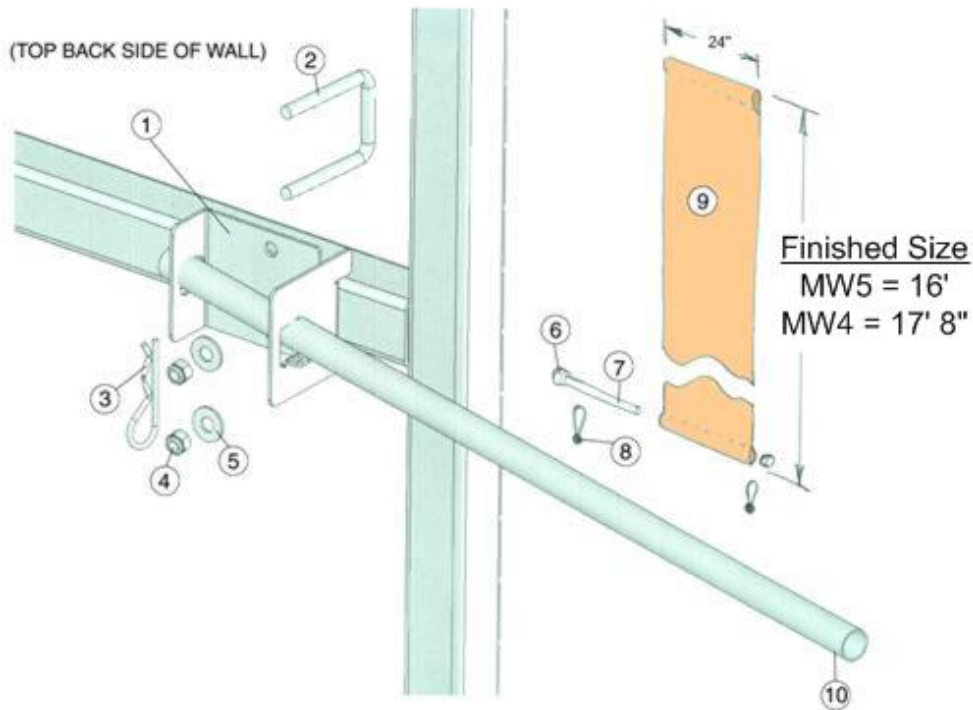

Mount the 4 Banner Brackets on the inside 2" x 2" cross members. The front banner brackets mount on the inside cross member of the tower frame at the top of the wall. The rear banner brackets mount on the cross member of the tower frame located mid-point of the Auto-belay, above the rear tire. Once the brackets are installed, they need not be removed.



Front Banner Bracket



Front Banner Bracket



Rear Banner Bracket



Rear Banner Bracket

Banner Kit Assembly Instructions

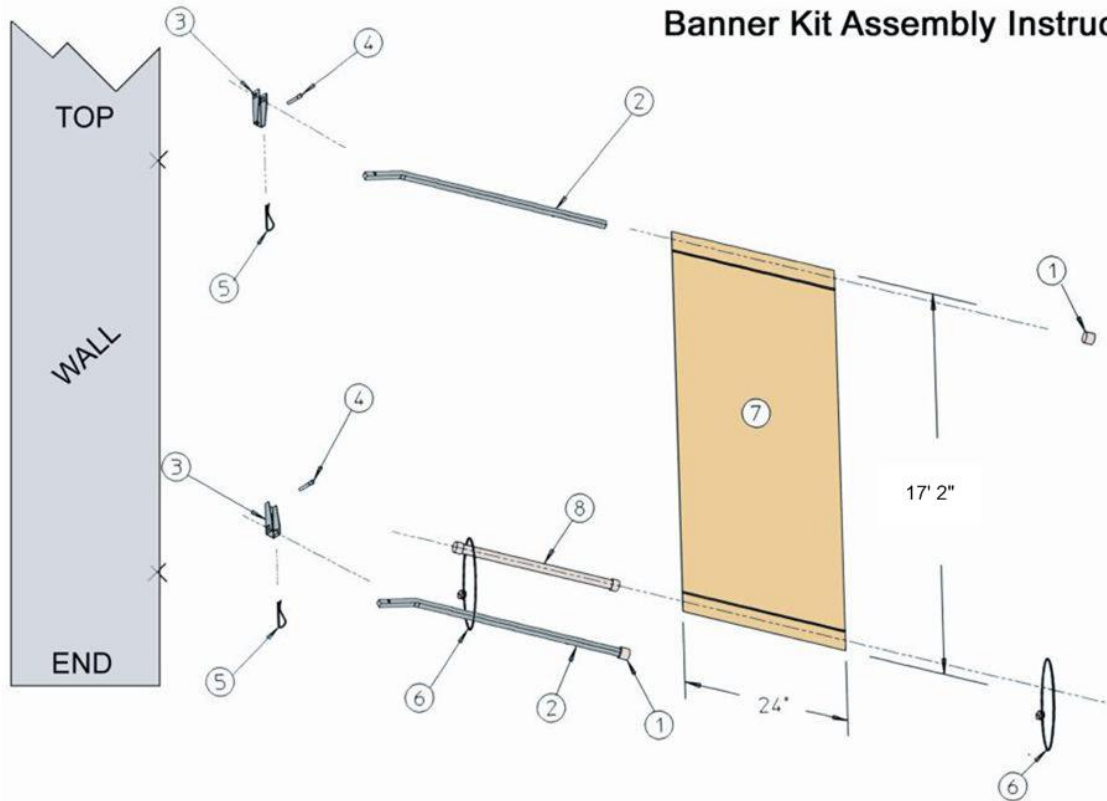

The brackets which hold the banner arms are permanently welded to the tower frame of the wall just above the rear of the fenders and just behind the side marker light at the top of the tower frame.

Top Banner Bracket

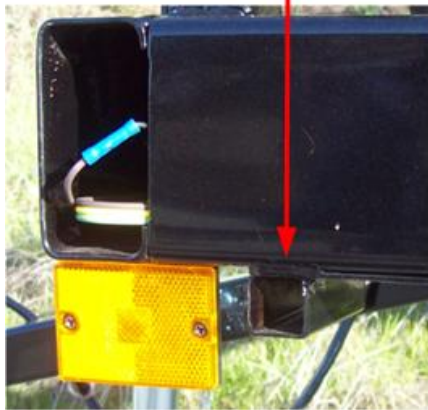

Bottom Banner Bracket



Attach your banners to the tower banner brackets. Attach steel banner arms into the brackets holding them in place with the pins or holding brackets (depending on whether you have an Space Saver 1 or NON Space Saver 1 style) at all four corner locations. Slide the banner sleeve over the top banner arms. Slide the PVC banner holder through the bottom sleeve of the banner. Attach the lower PVC banner holder to the bottom banner arm using the supplied bungee cords to keep the banner positioned in place during the wall operation.

Banner Sizing. The unfinished finished size of the banner is six inches longer than the finished size. The extra 6 inches in length of the unfinished size is for folding over and sewing pockets at each end of the banner for the banner arms. The pockets are then slipped over the banner arms.

NOTE: Reference the previous drawings for banner sizing or your particular model. Since the banner brackets may vary in position during manufacturing, it is better to wait until you have your product before having the banners made. This will ensure your banner will fit your product. The bolt on banner brackets can be relocated to the different cross beams of the tower frame to make shorter banners if desired. The Space Saver 1 style brackets cannot be relocated.

7. Operating The Wall



CAUTION: Read all instructions before operating the mobile climbing wall.

CAUTION Climbing is a physical activity and all possible care should be taken to ensure the safety of the climbers, spectators, and operators. Always operate the mobile climbing wall according to the procedures described here.

7.1. Operating techniques

Make sure to keep the landing area clear of spectators. It is recommended to have at least 6 to 8 feet clear in front of the mobile climbing wall for a “climbing zone.”

Use a minimum crew of two members.

Crew member #1

- Takes money (or tickets, or tokens, if money is taken elsewhere)
- Helps the climbers complete release forms (may be necessary)
- Harnesses the climbers
- Sends climbers to crew member #2

Crew member #2

- Hooks up the climbers
- Collects tickets or tokens (if used)
- Supervises climbers on the wall
- Unhooks the climbers
- Sends climbers back to harness area
- Advises climbers (acts as the coach)
- Solves problems with climbing

When not in use, you must keep the Auto-belay cables attached to their corresponding bolt hangers near the bottom of the wall. If you accidentally release a cable, it will automatically retract to its davit at the top of the wall, and you will have to retrieve it manually.

The coach (crew member #2) should be the only non-climber in the landing area.

After the climber's time is complete, unhook the climber and have him or her go to the harness area for removal of the harness.

To ensure maximum safety and provide easy and quick setup for climbing, use Extreme Engineering's Speed Harness™ for your climbing harnesses during your events. They increase your cycle time, are faster and safer to put on, and last longer than any standard harness on the market.

7.2. Safety Rules For The Operator

- ✓ Don't climb on the back side of the wall or its supports
- ✓ Don't stand on top of the wall
- ✓ Don't stand underneath a climber while climbing is in progress
- ✓ Don't leave the mobile climbing wall unattended while climbs are in progress
- ✓ If you must leave the wall unattended (while not in use), make sure that the Auto-belay cable is not accessible. This may be difficult, so the best solution is to keep one crewmember at the wall at all times.
- ✓ Using the optional safety cover is highly recommended, to prevent unauthorized climbing.
- ✓ Don't let a climber put on or take off a harness. You must always do this.
- ✓ Don't touch any pulley or cable within the wall structure while the Auto-belay is operating. If you must handle an Auto-belay cable while a climb is in progress, it should only be a cable on the climbing side of the wall, and as described in the special situations section below.



CAUTION: Don't wear any loose clothing, such as scarves, neckties, etc., while operating or inspecting the ride, to prevent the possibility of your becoming entangled in the ride's moving parts.

7.3. Safety Rules For Climbers

It's a good idea to make climbers aware of some simple rules. We suggest you reproduce these rules as a poster or handout for the climber (and his or her parents) to read. The following page is ready to photocopy, if you wish. Contact Extreme Engineering via email for an electronic format of the safety rules.

Safety Rules

Mobile Climbing Wall

CLIMBER RECOMMENDATIONS

- ✓ Must weigh 45 lbs minimum, 250 lbs maximum to wear climbing harness.
- ✓ Climber must fit in the harness to be allowed to climb.

BEFORE YOUR CLIMB STARTS

- ✓ After you are hooked into your harness, stay in the harness area. Wait until the operator tells you to go to the climbing area.
- ✓ Don't step on the Auto-belay cable while you wait to start.

DURING YOUR CLIMB

- ✓ Stay on the climbing route for your station.
- ✓ Don't cross over to put yourself directly beneath or above other climbers.
- ✓ Don't climb without shoes or a top.
- ✓ Don't climb beyond the wall top. Don't go beyond chest-height to the wall top.

DURING YOUR DESCENT

- ✓ Don't kick off more than 4 feet from the wall.
- ✓ Rappel straight down, and don't swing too close to other climbers.
- ✓ Be alert for other climbers beneath you, who may have strayed from their routes.

AT THE END OF YOUR CLIMB

- ✓ When you are lowered to the ground at the end of the climb, land on your feet.
- ✓ After your climb is complete, wait for the operator to unhook you.
- ✓ Once you have been unhooked, go to the harness area where we will remove your harness. Please DO NOT try to remove the harness yourself.

7.4. Special Climber Situations

The vast majority of climbs take place without any difficulty or interruption, but sometimes a problem can occur. Here's what to do.

Climber frozen at top

- Ask the climber to stay calm. Say that you are going to come up and the climber down.
- Put on a harness.
- As the climber next to the frozen climber finishes climbing, clip into the Auto-belay cable and climb the wall.
- When you reach the frozen climber, show the participant the climbing holds to climb down.

NOTE: Encouraging the climber to rappel down generally will not work.

Climber reports discomfort

- Ask the climber to stay calm. Ask if the climber is comfortable rappelling down. If so, then ask the climber to do so (if not, follow the procedure for "Climber frozen at top" above).
- If there is a problem with harness comfort, then adjust the harness, and let the climber begin climbing again.
- If a climber is unable to resume for whatever reason, unhook and send the climber back to the harness area.

Climber is intentionally reckless

- Ask the climber to take it easy. Choose one of the following options if he or she persists:
 - a. If you DO NOT believe adjacent climbers would be endangered, tell the reckless climber to rappel down or climb down now;or
 - b. If you believe other climbers might be endangered, tell the reckless climber to freeze at their position, and ask the other adjacent climbers to rappel down first (you can let them restart once the reckless climber is removed from the wall). Then, tell the reckless climber to either rappel down or climb down.
- Unhook the climber and send the climber back to the harness area.

Climber too light to rappel down

- Ask the climber to stay calm.
- Put on a harness
- As the climber next to the frozen climber completes their climb, clip into the Auto-belay cable and climb the wall.
- When you reach the climber, grab the climber's Auto-belay cable. Then your weight and the climber's weight will cause both of you to safely rappel down.

Auto-belay cable retracts to top of wall

- Put on a harness
- Clip onto another available Auto-belay cable and climb wall.
- Grab the loose Auto-belay cable and bring it down. When you get to the bottom, attach it to a bolt hanger at the bottom of the wall.

8. End of Event Takedown



CAUTION: For your safety, read all instructions before taking down mobile climbing wall.

CAUTION: Keep the area clear of people, cars, etc., during all steps of the takedown.

Clear the area of items used in operating the mobile climbing wall, including stanchions, crowd control barriers, etc.

Clear the area of people and cars.

8.1. Lower the wall



CAUTION: Keep the area clear of people while lowering the wall. Also make sure there is nothing resting on the trailer base frame that might prevent the wall from completely lowering onto the trailer base.

Release the Auto-belay cables. Disconnect each Auto-belay cable and allow it to retract completely to the top of the wall by itself.

Attach the hydraulic lift pump controller. Insert the metal plug attached to the controller to the controller socket attached to the pan of the trailer base. The socket is found at the rear of the base on the left side trailer pan near the fender mounting bracket. Raise the protective cover of the socket and fully insert the controller plug.

Raise the base of the tower frame off the ground. For the Space Saver 1 swing arm jacks, raise the jacks enough to get the jack to clear the ground. Swing the swing arm jack to its fullest rearward position. Lift the holding pop pin and continue to push the swing arm until it is up against the trailer frame. Release the pop pin and then pull out on the swing arm jack to ensure the pop pin is engaged and holding the swing arm in place. Perform this action on the opposite side swing arm jack as well.

Using the rear jacks, raise the mobile wall frame that has been sitting on the ground surface during operation up until there is a minimum of 2 inch clearance between the frame and the ground surface. Rotating jack handles clockwise raises the wall. Ensure the wall is level from both the side view as well as from the rear view, raising or lowering jacks as appropriate to maintain the wall in the exact vertical position and to allow the ground clearance.

Lower the wall with the controller. Press down on the controller toggle switch to lower the wall. While the wall is lowering listen for any abnormal sounds. Watch all around the perimeter of the operational area to ensure individuals or objects will not be hit while lowering the wall.

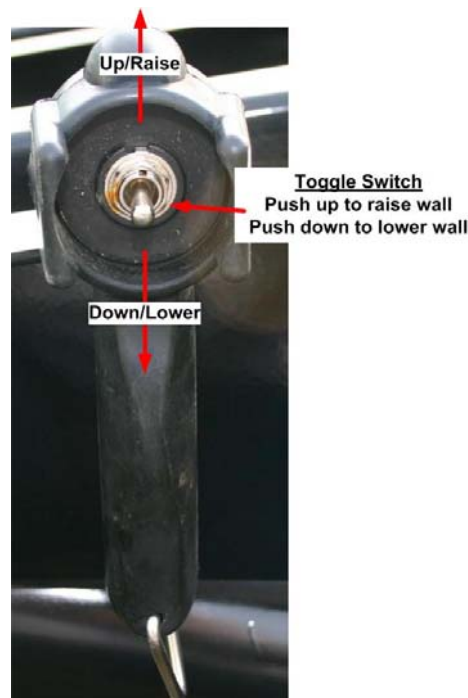

Lower the wall to the horizontal position in one *continuous* motion. Try to avoid pressing the DOWN direction on the toggle switch multiple times during the lowering cycle. **Do Not** continue to force the wall any further than it's completed horizontal position with the tower frame resting on the tower rest. This can cause damage to frame members.



WARNING: Never hold the down button for longer than two seconds after the tower frame has rested onto the tower rest of the base frame. Holding the button longer than two seconds will damage the base frame, tower frame and upper hinge lift arms.

If the wall is lowering slower than normal, this could be a sign of a weak charge on the battery.

In an emergency, to lower the wall with a weak battery, the battery can be hooked up to the tow vehicle battery temporarily to complete the lowering cycle. Once the wall has been lowered successfully, disconnect the jumper cables.

If the wall had to be raised with the help of the tow vehicle, it will also require help when lowering. The default operation of the pump is to raise the wall. When battery power drops below a sufficient level, the direction control module will not engage when the pump is running. The direction control module reverses the flow direction of the hydraulic oil and this causes the wall to lower. If the direction control module does not engage, the pump will only attempt to lift the wall further. It will not lower.

It is possible that there is sufficient charge to raise the wall during the lift cycle, but that drains the battery enough to where it won't lower due to the inability to engage the direction control module. In both of these cases, you will have to connect the tow vehicle battery to the mobile wall battery to lower the wall.

Attaching the battery is the same as with jumping another vehicle that won't start. Attach the positive jumper cable lead to the positive post on the mobile wall battery. Attach the negative lead to the negative post on the mobile wall battery. Make sure that the opposite ends of the negative and positive leads on the jumper cables DO NOT touch each other or any portion of metal on either the mobile wall or the tow vehicle inadvertently. Attach the positive lead to the tow vehicle's positive battery post. Lastly, attach the remaining negative lead to a good solid metal ground point on the tow vehicle. Start the tow vehicle and then lower the wall using the controller. Carefully disconnect the leads by first disconnecting the negative cable from the vehicle ground point and the positive battery post. Remove the negative lead from the mobile wall battery and then remove the positive lead from the battery.

Unplug the controller and store it safely away.

Pack up any shims which were under the wall base, and stow them in the optional trailer toolbox or in the tow vehicle.

If you have not already done so, retract the Auto-belay cables. Disconnect them from the bolt hangers near the base of the wall and walk the cables up to the top of the wall. Let the cables fully retract up to the davit pulleys. **DO NOT** allow the cables to retract by themselves when the wall is in the horizontal down position.

Attach Auto-belay cables for travel. Allow the Auto-belay cables to retract fully to the top of the wall. To prevent damage to the cables, mobile wall, passing vehicles, or possible injury to pedestrians during travel, connect the two outside cables on each side of the wall together using the carabiners.



CAUTION: DO NOT tow the mobile wall with without securing the two lowest outside Auto-belay cables.

8.2. Prepare The Wall For Transport

Move the jacks around to their proper travel position. One of the jacks always needs to be relocated to the tongue jack position for allowing hook up to the tow vehicle hitch.

If one of the axles dropped down during raising the wall, it will relocate properly once you are driving down the road. This may not happen immediately upon moving the wall. It may take a bump in the road to cause the axle to relocation to its proper towing position. This is a normal condition.

Back the tow vehicle into position so that its towing ball is positioned under the mobile climbing wall's trailer tongue. If you have a second operator, have him or her stand by the trailer to guide you into position. Position the tow vehicle's hitch as close as possible to the tongue of the trailer with the trailer coupler as close to directly above the towing ball as possible. Position the vehicle to minimize having to manually move the trailer into place.

Follow section 2 and 3 of this manual for attaching and towing the mobile climbing wall.

9. Troubleshooting

If you have a problem with your mobile climbing wall, check the following table for solutions.

| Problem and Solution |
|---|
| <p>Jacks don't extend or retract</p> <ul style="list-style-type: none"> • Keeper pins may still be in place. Remove the keeper pins. • Dirty jack inner ram tube. Remove obvious dirt, and then spray a little silicon lubricant to loosen the jack and extend it. When fully extended, clean the inner ram tube carefully and apply a light coating of silicon. |

Wall won't raise or lower

- Wall's lockdown pin is still in place. Remove the lockdown pin.
- Controller malfunction. Make sure controller cable is not damaged. Wires may have been pulled loose in connector or receptacle.
- Loose connector on hydraulic pump. Check and tighten connector.
- Battery is low. Check the battery and recharge if necessary.

Wall seems unstable

- Surface not level. Make sure the setup surface is level. Add minimal shims as necessary.
- Shims poor. If you have used shims to level the wall, make sure they are solid, stable, and not stacked to a height of more than 1 ½”.
- Poor wall location. Move the wall to a more solid, level location.
- Windy. If wind conditions are too strong, lower the wall and don't use it until conditions improve.
- Outriggers are not properly or fully deployed. Deploy, secure, and level.
- Wall is not vertical. Check by leveling and adjust jacks as needed.

Belay in the Box Auto-belay cables won't extend

- Pulley problems. Make sure the pulleys are turning smoothly and that the cables are not jammed.
- Cables binding. Replace any worn parts causing binding.

Belay in the Box cables won't retract

- Low pressure in the air tank. Add air to the tank to bring the pressure up to 60-65 PSI with the cable attached to the eye bolt at the bottom of the climbing panel.

Brake lights/tail lights/turn signals don't work

- Connector loose or not connected. Make sure the trailer light/brake connector cable is firmly connected to the tow vehicle.
- Blown fuse in the tow vehicle. Inspect the fuse and replace it if necessary.
- Broken wire. Make sure the connector cable is not damaged.
- Broken or burnt-out light bulbs. Replace the broken or dead bulbs.

10. Frequently Asked Questions

What type of vehicle or additional equipment is needed to tow the portable wall?

Depending upon model, Extreme Engineering's products weigh between 2500 and 6000 lbs. A class 3 or 4 tow hitch must be used. The ball size is 2 5/16" or current and the wire harness is a standard RV 7 way connector or a standard flat 4 way connector. The brake control (for the trailer brakes) and wire harness are standard installation for most RV centers and U-Haul facilities.

What type of insurance do I need, how much does it cost, where do I get it?

Most events require liability insurance. The cost can vary. We provide a list of insurance providers that are familiar with our equipment and requirements.

Is financing available?

Yes. Call Extreme Engineering at (916) 663-1560 for a list of recommended financial institutions.

How much maintenance is required?

As with any equipment, general maintenance is required. However, maintenance tasks are simple and can be done yourself. A general log is recommended and the average maintenance for our customers depends on the amount of use of the product.

How long does it take to set up a mobile wall?

The set up time is approximately 15 – 30 minutes. All mobile walls can be set up with one person. The push button hydraulic lift on Extreme Engineering mobile products make it safe, fast and easy!

Are there different levels of difficulty on the mobile climbing walls?

Yes. The wall designs provide different levels of difficulty; however, Extreme Engineering makes sure that the wall isn't too difficult to climb. We offer over various climbing hold placements for rerouting the wall, allowing you to set the difficulty level higher or lower. The climbing holds can be easily moved and adjusted for any combination or configuration you want.

How durable is the climbing surface?

The simulated rock finish is a polyester resin with a long fiber E-glass matrix, making it waterproof, wear resistant, and extremely durable for many years of use. The polymer technology is also designed for many years of.

How do I clean the wall and climbing holds?

Most of our customers find it easy to go to a "coin-op" car wash. **DO NOT use high pressure wash nozzles on the polymer style climbing panel.** High pressure can be used for the fiberglass style climbing panel.

What is a short footprint trailer?

The footprint is the actual space dimension on the ground when the mobile climbing wall or other Extreme Engineering mobile product is set up. Due to our unique, patented (US PAT# 6,083,142) trailer base, the footprint is only 16' x 8' (depending on configuration). One of the many advantages of the short footprint is the ability to fit inside areas that are limited in space. Many events charge vendors by the square foot. Fewer square feet equates to less money out of your pocket!

What types of events are most popular?

Fairs, festivals, school carnivals, graduation nights, college events, private parties, corporate team building, company picnics, radio promotions, store sales, parks and recreation events. The list is endless and is based on your creativity!

What are the typical gross earnings potential?

Similar to most businesses, returns vary depending on the individuals running the business and the venue. Here are some potential numbers, for a Three-climber wall:

- Average time per climber: 3 minutes
- Climbers per hour with harness time: 45
- Average per climber price: \$3-\$6
- Average hourly price: \$200-\$300
- Average Per Climb Income: 45 climbers per hour at 8 hours of climbing time at \$5 per climb equals \$1800 per day.
- Average Hourly Charge Income: 8 hour event at \$225 per hour = \$1800 per day

My Auto-belay is leaking oil out of the breather.

Is the fluid clear or red in color? If the oil is clear and the hydraulic cylinder is new, this is normal for some to leak out. The clear fluid is an assembly fluid and will soon work it's way out of the ram. If the fluid is red, it is not uncommon for a little weeping to occur. However if the system is loosing air pressure (10 to 15 psi per month), the cylinder must be replaced.

My Auto-belay is spewing or leaking oil.

Spewing or leaking oil is a safety issue and ram should be replaced. During the ram replacement procedure always ensure that fluid levels are correct.

My Auto-belay has lost pressure, below 55 PSI.

The correct pressure for an AB-34 (Mobile 2, 3, 4 and 5 climbers) is 65 to 65 psi when the cable is fully extended and attached to the eye-bolt at the bottom of the climbing panel. For a AB-52 (Mobile 5 Climber 35 foot tall) is 75-85 psi when the cable is fully extended and attached to the eye-bolt at the bottom of the climbing panel. If an Auto-belay is loosing pressure due to fluid loss and the tank is re-pressurized without first resolving the leaking, the Auto-belay runs the risk of running out of fluid. Operating an Auto-belay low on fluid is a safety issue. To correct problem; Check fluid level (see procedure). Using a soapy water solution, you can look for air loss at the various fittings, hoses and other connections. Wet each joint and look for bubbles. If bubbles appear, tighten or re-seal the connection as appropriate for the type of connection (compression versus sealed fittings).

My Auto-belay 'dropped' a climber a few feet.

Immediately stop using that Auto-belay. If the climb is the first climb of the day, the Prime Before You Climb operation was not successful. It also may mean the Auto-belay fluid level has dropped below the critical level as seen in the site glass on the side at the bottom of the air/fluid tank. If the auto-belay is low on fluid, see the check and refill section. Contact Extreme Engineering for troubleshooting advice.

I cannot LOWER my wall.

Check battery level by using jumpers to a running vehicle. Hook up the jumper cables the same as you would when attempting to jump start a vehicle. Check all battery cables for corrosion and tightness. Check all wires from plug on trailer-side to battery and pump motor looking for loose connections. Check controller-side plug for loose connections. Remove plug cover and inspect wires/connections.

I cannot RAISE my wall.

Check battery level by using jumpers to a running vehicle. Hook up the jumper cables the same as you would when attempting to jump start a vehicle. Check all battery cables for corrosion and tightness. Check controller-side plug for loose connections. Remove plug cover and inspect wires/connections.

My pump makes sounds when I try to operate the controller but nothing happens with my wall.

Check battery level by using jumpers to a running vehicle. Hook up the jumper cables the same as you would when attempting to jump start a vehicle. Check all battery cables for corrosion and tightness. Check controller-side plug for loose connections. Remove plug cover and inspect wires/connections. Check the automatic transmission fluid level in tank.

11. Maintenance

Your mobile climbing wall will give you years of trouble-free service if you take care of it. For safety, trouble-free operations, and good appearance, follow the maintenance schedules provided here.

Log Book

A maintenance log book is essential for tracking the use of the Extreme mobile climbing wall. If you record the date, number of daily cycles, and number of cumulative cycles, this record will allow you to anticipate when some maintenance tasks (such as replacing an Auto-belay cable) should occur. We have a maintenance log sheet included on page 48 of this manual.

Maintenance procedures and inspection logs

Read the inspection procedures on the following pages. Be sure to use copies of the inspection checklists provided in this manual to keep a record of your inspections.

Detailed description of inspection items

Inspect the mobile climbing wall thoroughly before you take it out to use it. Your safety on the road, during setup and your climbers' safety depend on it!

Auto-belay cable

Check the cable for fraying, broken strands, kinks, wear or damage. Run your hands along the entire length of the cable, checking for a wavy or uneven feel to the cable. We recommend wearing leather gloves when checking the cable. If you hit a broken strand or frayed section of cable, it can hurt your fingers!

ALWAYS REPLACE YOUR CABLES EVERY YEAR OR 10,000 CLIMBING CYCLES, WHICH EVER COMES FIRST. YOU, YOUR STAFF, AND YOUR CLIENTS DEPEND ON IT.



CAUTION: Always replace any suspect cable. This is absolutely critical for safe operation! If you suspect a cable is damaged, or are not sure, visit our tech page at www.extremeengineering.com or call Customer Service for assistance before operating the system!

Only order Extreme Engineering certified cables. Extreme Engineering uses the highest grade cable available. Auto-belay cables should be replaced every 12 months from date of manufacture or 10,000 climbing cycles (a climb cycle is once up the wall and once down the wall), which ever comes first even if there are no signs of wear.

Auto-belay pulleys

Make sure the cables are traveling through the pulleys without binding. Make sure all the pulleys are turning smoothly and are not worn.

Auto-belay system

Inspect the Auto-belay system thoroughly for wear in the pulleys or cables. Call Customer Service for assistance in ordering and replacing pulleys and cables. Replace lock nuts after any Auto-belay servicing.

Make several climbs on the Extreme mobile climbing wall. Be sure that the cables retract smoothly, and your descent is smooth, without any halts or jerky motion.

Hydraulic Hose

Make sure the hose isn't leaking. If you find a leak, call Customer Service for assistance.

Air Tank

Make sure the pressure in the air tank is at the correct pressure, 60 to 65 PSI (Mobile 2,3,4 and 5 climber models) or 75 to 85 PSI (Mobile 5 Climber 35 foot tall) with the cable extended, or as otherwise marked on the tank.

Wall lift system

Raise and lower the wall. Make sure the wall lifts smoothly and completely. If the wall does not raise or lower completely, or there is any hesitation in its motion, contact Customer Service.

Check that all connectors on the hydraulic lift pump are properly tightened (control cable, power, and ground). Tighten if necessary.

Jacks

The Extreme mobile climbing wall has a total of four: the two outrigger extending jacks, and the two front jacks.

Let out each extending jack as far as possible and clean the inner ram tube. Coat the tube with a light coat of silicon spray lubricant.

Trailer Hitch

Make sure the trailer hitch is of the proper weight capacity and the towing ball is a 2-5/16" diameter. Inspect the safety cable and its mounting hardware for wear. If at all questionable, replace it.



CAUTION: If you are in any doubt about the hitch or the safety cable, consult Extreme Engineering or an automotive or RV service center. This is critical for safe transport. A trailer becoming unhitched during transport can be a catastrophic.

Trailer tongue

Make sure the bolts holding the trailer tongue to the trailer are tight.

Trailer wheels

Make sure the lug nuts are tight. Lug nuts should be checked every 500 miles.

Trailer lights

Connect the trailer light and brake connector to a towing vehicle. Be sure the taillights, brake lights, running lights and turn signals are performing correctly.

Replace any broken or burnt-out bulbs. Keep spare bulbs on hand. When troubleshooting non working lights, remember to check the tow vehicle's fuses also and replace as necessary.

Check for broken light lenses and replace if necessary.

Loose or broken parts

Inspect the entire mobile climbing wall for loose or broken parts. Replace broken parts (call Customer Service to order) and tighten loose parts.

Hitch pins

Hitch pins are an additional safety measure for their intended use. Keep spares on hand. Only replace with equal quality.



CAUTION: For both use and transport, never modify, alter, or adapt your equipment with anything other than the correct keeper pins or safety snap pins! Doing so could create a serious hazard!

Harness

Protect your harnesses from constant direct sunlight and heat and from nylon-damaging substances such as acids, alkalis, oxidizing agents, and bleach.

Carabiner

Make sure the carabiners lock properly. All surfaces of the carabineers should be free of cracks, sharp edges, corrosion, burrs, or excessive wear. Be sure the gate and any locking mechanism closes freely and completely. Gate opening and closing should be quick and easy. If washing and drying does not remedy a gummed-up carabiner, replace it. Replace carabiners if they are worn or damaged.



CAUTION: If a carabiner does not pass inspection (even after cleaning), destroy and replace it with a new one. This is absolutely critical for safe operation. Always keep a spare carabiner on hand.

12. Replacing Auto-belay cables

12.1. Mobile Wall Air Pressure Release

If the cables are attached to the eye-bolts at the bottom of the climbing panel, release them and allow the cable to retract to the top of the wall.

With the wall in the fully down position, remove the tower lockdown pin and raise the climbing tower three to four inches up off of the tower rest.

The reason for this is the oil level in the auto-belay tank, from the factory, is slightly above the mid-point level of the reservoir tank capacity. With the wall in a level (horizontal) position, the automatic transmission fluid will spew out of the air fill valve when releasing the air pressure. Raising the front of the wall three to four inches above horizontal will cause the fluid to drop down below the air fill valve level. It is normal for a small amount of oil, or vaporized oil to appear around the air fill valve when releasing air pressure.

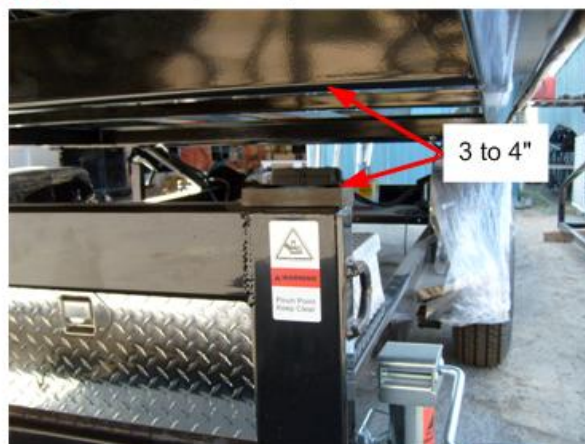
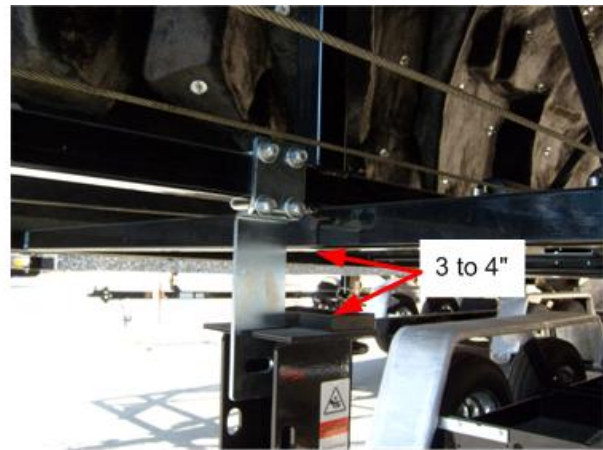
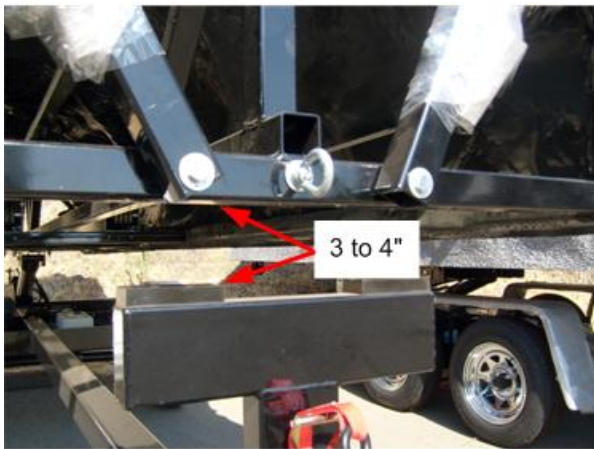

Remove the tower lockdown pin and slightly raise the tower of the mobile wall. Release the air pressure from all auto-belays which you are replacing the cables on. To release the pressure, remove the small black rubber cap from the air fill valve. To prevent oil that may remain in the air fill valve from spraying, hold a rag over the air fill valve while releasing the

air pressure. Using a small screw driver, carefully press inward on the fill valve pressure release pin. Be careful not to bend or press too hard on the pressure release pin while releasing the air pressure. Drop the air pressure down to zero as indicated on the air pressure gauge next to the air fill valve.

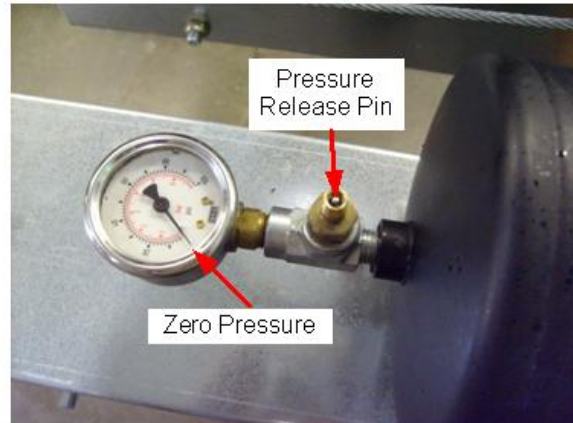
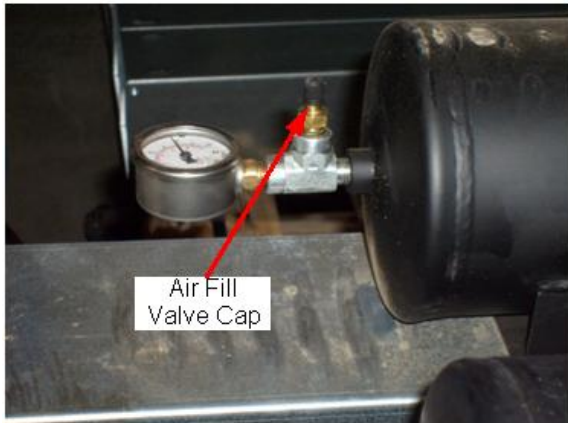

Once all air pressure has been released from the auto-belays receiving a cable replacement, lower the tower back down onto the tower rest.

12.2. Remove The Auto-belay Box Covers

Remove the bolts that hold the covers in place using an SAE 7/16" socket or wrench. There are a total of 18 bolts with internal tooth lock washers to remove, 3 on each side of the top and bottom covers.

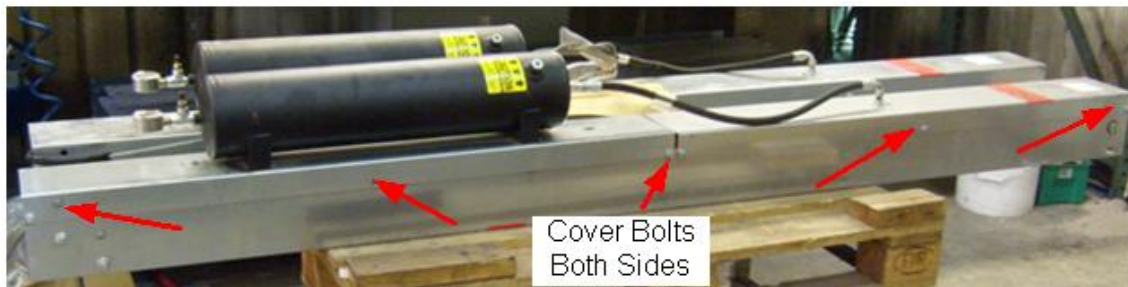

Move the cover with the air/hydraulic fluid reservoir off to the side to provide access to the cable inside the top of the auto-belay box. When moving the cover off to the side, be careful not to damage the hydraulic hose between the tank and the lower half of the auto-belay.

If you are changing cables on a stationary wall, find a way to hang the tank/cover from the steel structure that the auto-belay is mounted to. DO NOT allow the tank/cover to hang by the hose anywhere as this will damage the hose.

The auto-belay hydraulic cylinder rams are positioned inside the lower portion of the auto-belay box. A pin at the bottom of the rams and auto-belay box is all that holds them in place. You cannot move the lower auto-belay box cover to the side due to the hydraulic fittings that connect the outside hose to the inside hoses. To provide room for changing the cable, raise the entire hydraulic assembly at the top of the lower cover. Raise the entire

assembly upward until you can insert an object that will rest on the top of the bottom auto-belay box sides and allow the hydraulic assembly to rest on the object. In the following example, a large screwdriver was used to hold the assembly up out of the auto-belay box. When raising the assembly and cover, be careful to not damage the hydraulic hoses and fittings both on the inside and outside of the Auto-belay.

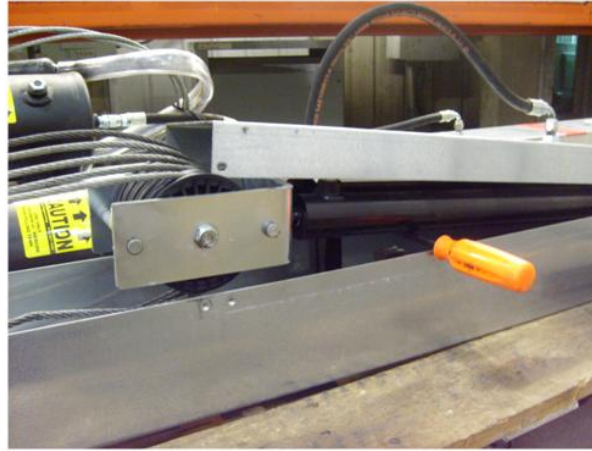

12.3. Remove The Rear Pin From The Pulley Bracket

Remove the snap ring from one side of the rear pulley bracket pin using external snap ring pliers. While removing, spread the snap ring apart just enough to allow it to be removed from the groove in the pulley bracket pin. If the snap ring is spread too far, it will not re-engage in the groove properly when it is placed back on the pulley bracket pin. Should the snap ring be spread too far, it will require replacement with a new snap ring. Push the pulley bracket pin out through the opposite side of the pulley bracket. Set the pulley bracket pin and the snap ring to the side for re-attachment later.

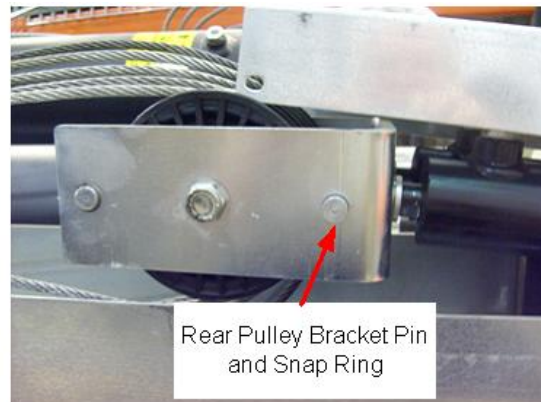
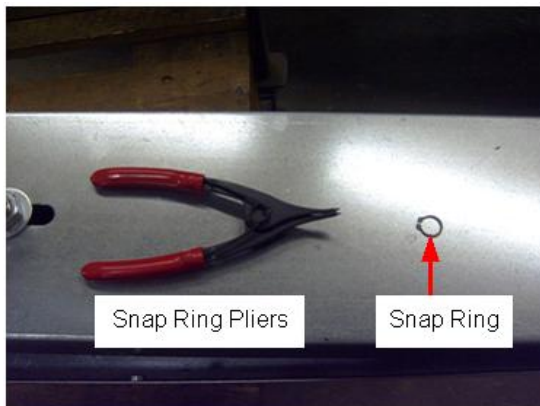

12.4. Remove The Internal Cable Mounting Bolt

Using two SAE $\frac{3}{4}$ " wrenches or sockets, remove the internal cable mounting bolt.

Older versions of auto-belays utilized a spacers between the auto-belay box and the marine eye attached to the cable on the inside of the box. Current auto-belay manufacturing utilizes 3 washers instead of the spacer. Set the bolt, nylock and washers/spacer to the side for re-attachment later.

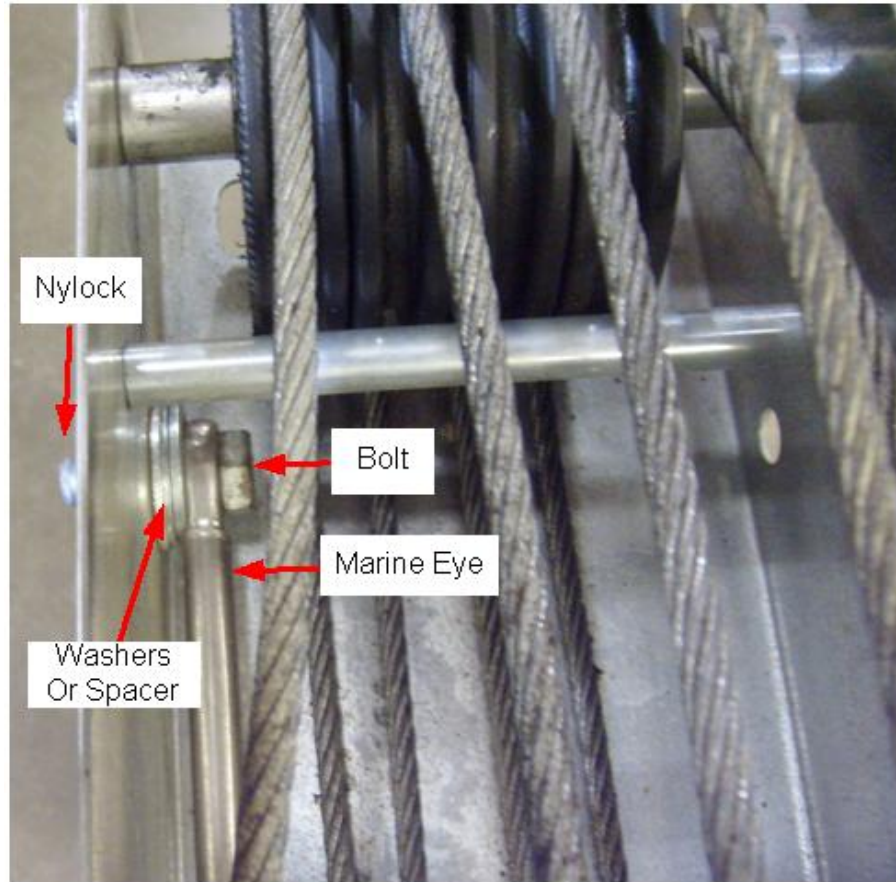

12.5. Remove The Cable

Remove the old cable from the auto-belay by pulling on the end of the cable that extends outside of the box. There is enough clearance for the marine eye to be pulled through between the pulleys and the pulley bracket attached to the hydraulic cylinders. Should the cable or marine eye get caught between the pulleys and the pulley bracket, you can help thread it through the area with your hands.

12.6. Safety Inspection Of Internal Components

Once the old cable has been removed, inspect all components inside the box for proper operation, damage or oil leakage.

Inspect all pulleys mounted at the top of the auto-belay box and to the pulley bracket. Ensure there is no damage to any of the pulleys. Check that all pulleys rotate smoothly and independently. When rotating a pulley, it should not rub against anything on either side of the pulley. There are machined spacers between each pulley to prevent them from rubbing against each other. Should a pulley rub against another, the spacer between them is either missing or damaged and needs to be replaced. Inspect pulleys for cracks or breakage. Any cracked or broken pulleys must be replaced.

Inspect all hydraulic fittings and hoses for damage or leakage. There should be no fresh oil residue beyond what may have occurred from the original Auto-belay manufacturing process. Any fitting leakage should be corrected either by additional tightening of the

connection or replacing of the fitting if tightening does not stop the leakage. If there is leakage found on the rubber hose portion of a hydraulic hose or between the rubber hose portion and the fitting that is directly attached to the hose, the hose must be replaced.

One possible exception to visible oil is from the breather cap installed at the very bottom of each ram.

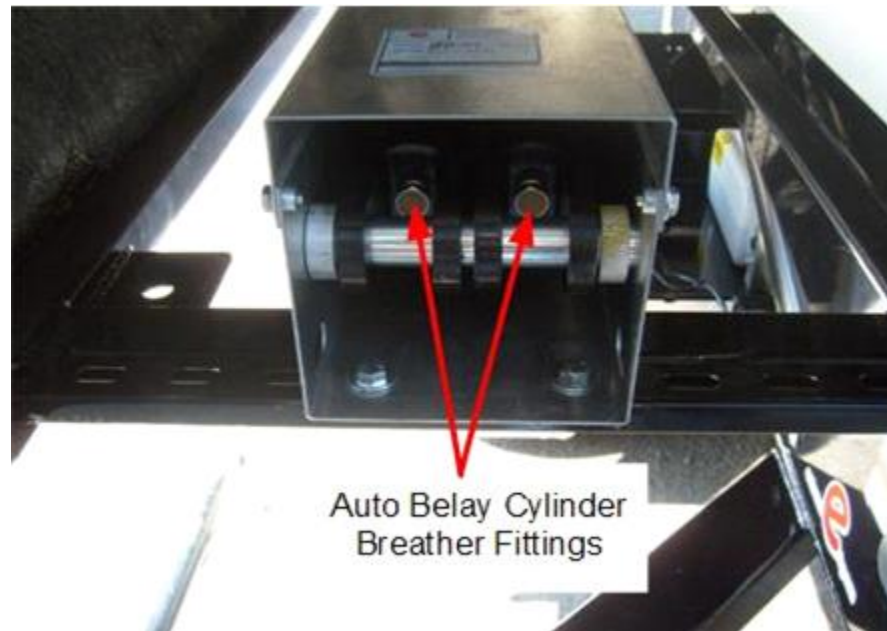

Extreme Engineering utilizes high pressure hydraulic cylinder rams in a low pressure environment. Therefore, a very small amount of weeping of oil may appear around the breather cap area of the auto-belay. This is considered normal.

If the oil residue is greater than the normal weeping amount, this may be an excessive leakage. Any hydraulic cylinder that is demonstrating excessive leakage must be replaced.

Excessive leakage can be determined as follows:

- If all three of the following conditions are true:
 - If you are having to add 10 to 15 psi of air pressure per month to the auto-belay air/oil tank, **and**
 - There is no oil residue seen from any other components inside and outside of the auto-belay other than around the normal weeping of oil at the breather cap on the bottom of the auto-belay cylinders, **and**
 - There are no air leaks coming from the auto-belay air tank, the hose attached to the air tank, the fittings and air pressure gauge attached to the air tank.
- You see visible oil dripping from the breather cap on a continual basis.
- You are at an event and you find a puddle of oil on the ground which originated from an auto-belay.

If at any time you are unsure whether an auto-belay is demonstrating excessive leakage, contact Extreme Engineering's Technical Support for further troubleshooting assistance.

12.7. Install New Cable Assembly

Replacement cables purchased from Extreme Engineering always come with a new swivel, protective swivel boot, protective cable hose and carabiner. DO NOT re-use the swivel. Discard the entire cable assembly.

Prior to replacing the existing cable, always determine which side of the auto-belay box the cable extends out of and which side the marine eye attaches to. String the new cable exactly like the existing cable. To install the cable, take the marine eye end of the new cable (the end without the swivel attached) and thread it in a looping fashion around each top and bottom pulley.

Drape the cable across the top of the spacer at the top of the auto-belay. Pull the cable down to the bottom pulley assembly (pulleys attached to the hydraulic cylinders). Place the cable in the groove of the pulley and wrap the cable over the top and back underneath the pulley. Pull the cable back up to the first top pulley on the same side. Bring the cable around from under this pulley back over the top with the cable in the groove of the pulley. Repeat this action until the cable has been wrapped around all pulleys from left to right. Pull the marine eye up to the top mounting hold on the side of the auto-belay box after completing the looping of the cable around all pulleys.

Ensure the cable is in the center groove of every pulley. Ensure the cable does not cross over itself anywhere throughout the loops.



12.8. Attach Marine Eye to Auto-belay Box

Re-attach the marine eye to the inside of the auto-belay box. Using the original $\frac{1}{2}$ " x $1\frac{1}{2}$ " bolt, place the bolt through the eye of the marine eye. Place the three $\frac{1}{2}$ " internal diameter hole washers over the bolt on the opposite side of the marine eye.

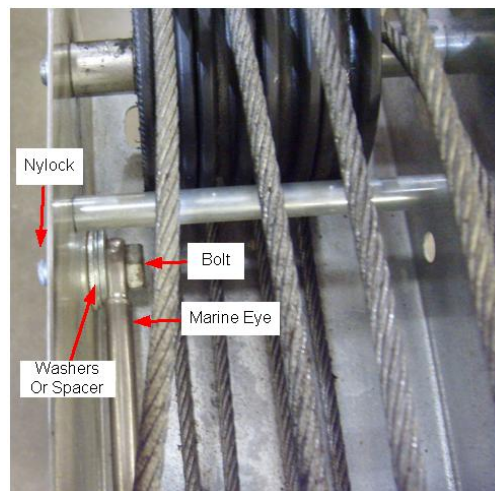

If your auto-belay cable originally contained a spacer instead of the three washers, there may be a clearance issue. Some marine eyes attached to the cable can be up to $\frac{1}{4}$ of an inch wider than others. This difference in width may cause clearance issues between the head of the attachment bolt and the cable loop nearest the bolt. If the head of the bolt does not clear the side of the cable by at least $\frac{1}{8}$ ", replace the spacer with three standard $\frac{1}{2}$ " internal diameter washers.

Push the bolt with marine eye and three washers through the auto-belay box from the inside. Place the nylock nut onto the bolt on the outside of the auto-belay box and tighten. **The nylock nut must be replaced every 3rd cable change.** The nylon locking nut is a standard SAE $\frac{1}{2}$ " nut with a size 13 thread.

The marine eye should be angled down toward the bottom of the auto-belay box to prevent clearance issues with the pulley bracket attached to the hydraulic cylinders when the auto-

belay cable is fully extended out of the auto-belay. Leave at least ¼ inch clearance between the bottom of the marine eye/cable and the bottom of the auto-belay box.

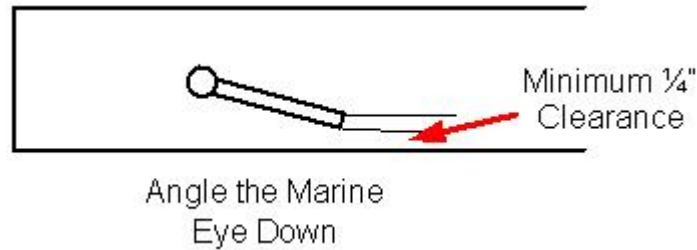

While holding the bolt on the inside of the auto-belay box with an SAE ¾" wrench, tighten the nylock nut with an SAE ¾" wrench or socket.

After tightening the bolt, check for clearances. Ensure there is clearance between the cable and the bottom of the Auto-belay box. Ensure the marine eye is at a downward angle toward the bottom of the Auto-belay box. Ensure there is clearance between the head of the bolt and the cable wrapped around the pulleys closest to the bolt.

12.9. Replace The Rear Pin On The Pulley Bracket

Re-insert the rear pulley bracket pin into the rear holes on the side of the pulley bracket. Using external snap ring pliers, spread the snap ring apart just enough to allow it to be placed over the end of the pulley bracket pin. Ensure the snap ring engages fully into the groove at the tip of the pulley bracket pin all the way around.

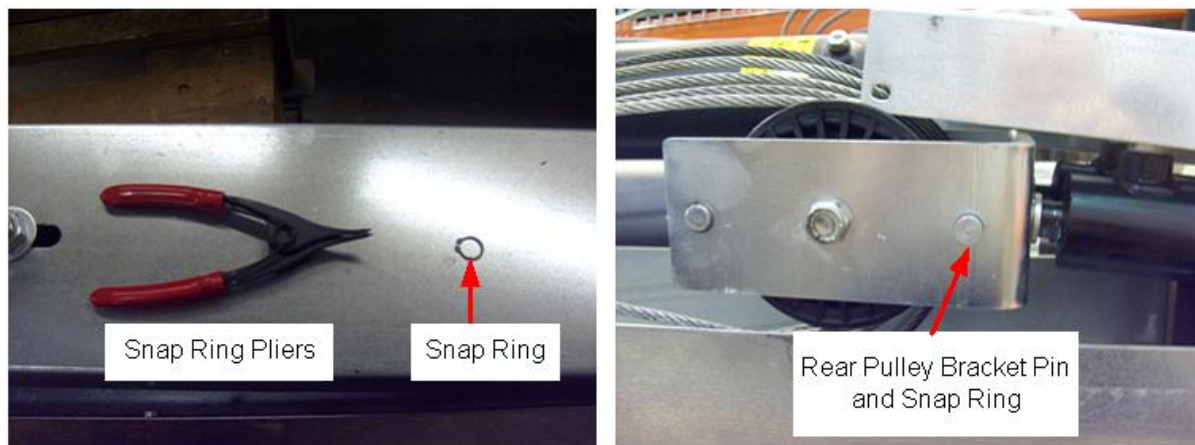

If the snap ring is spread too far during removal or replacement onto the pulley bracket pin, it will not re-engage in the groove of the pin properly. Should the snap ring be spread too far, it will require replacement with a new snap ring.



WRONG
Gap between
snap ring and pin



CORRECT
No gap between
snap ring and pin

12.10. Re-Attach Auto-belay Covers

Carefully lower the entire cylinder/pulley assembly back down onto the rubber saddle inside the auto-belay box. Place the lower auto-belay cover over the bottom portion of the Auto-belay box and align the mounting holes. Place the original small bolts with internal tooth lock washer into the holes to re-attach the bottom cover. Using an SAE 7/16" socket or wrench, tighten all nine bolts.

Re-attach the upper cover with the air/oil tank over the top the auto-belay. Place the small bolts with internal tooth lock washer into the holes to re-attach the top cover. Using an SAE 7/16" socket or wrench, tighten all nine bolts.

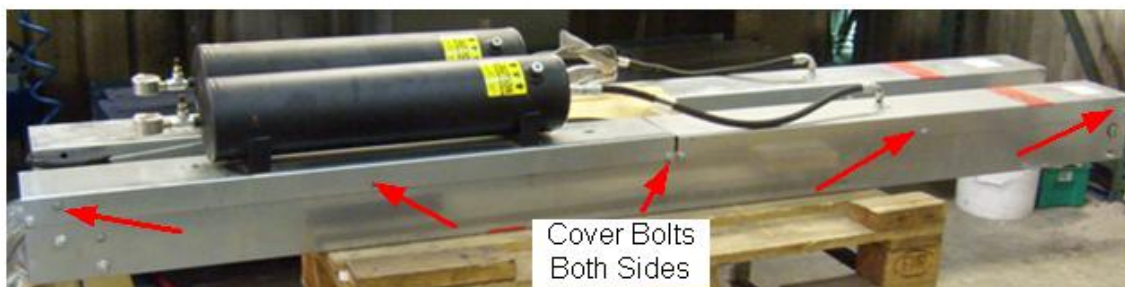

12.11. Cable Replacement Completion

To complete the removal of the old cable, you will need to remove the davit pulleys attached to the davit arms at the top of the wall.

Prior to removing each davit pulley assembly, note which side of the davit arm the davit pulley assembly is bolted to. Ensure you place the davit pulley assembly back onto the same side of the davit arm when re-attaching. Using two SAE 3/4" wrenches or sockets, remove both the upper and lower Davit Pulley assembly which the old cable passes through.

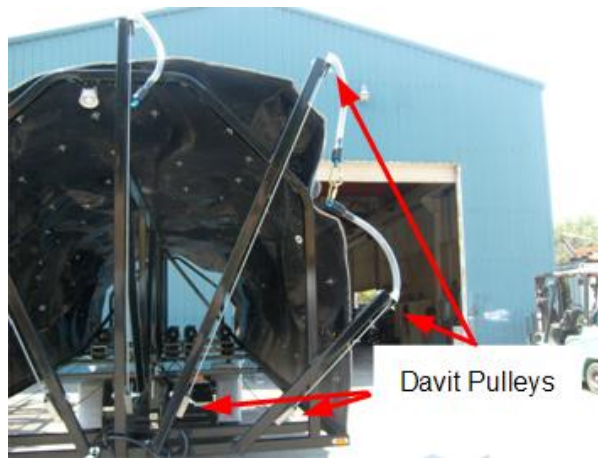

Place the new cable in the davit pulley assembly. Ensure that the cable is not wrapped round the tower frame anywhere between the auto-belay and the lower davit pulley at the front of the tower frame and between the lower and upper davit pulleys.

To place the new cable into the davit pulley assemblies, start by holding the davit pulley shield in one hand with the opening facing up. Lay the new cable through the shield. Place the pulley on top of the cable ensuring the cable is positioned in the groove of the pulley. Place one washer over the davit pulley assembly mounting bolt. While holding the shield and pulley with one hand, with the other hand insert the bolt through the hole in the shield, through the hole in the center of the pulley and out the other side of the shield. Place the davit pulley assembly back on the same side of the davit arm that it was originally removed from. Place the second washer over the bolt and then place the nylock nut onto the bolt.



1. Lay cable through davit shield



2. Lay pulley on top of cable with cable in groove of pulley



3. Bolt with washer through hole in shield and pulley

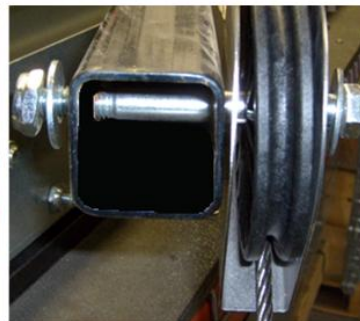

4. Washer and Nylock nut on outside of davit arm

Position the davit pulley shield for equal clearance between the cable and the shield at the point where the cable enters and exits the pulley assembly.

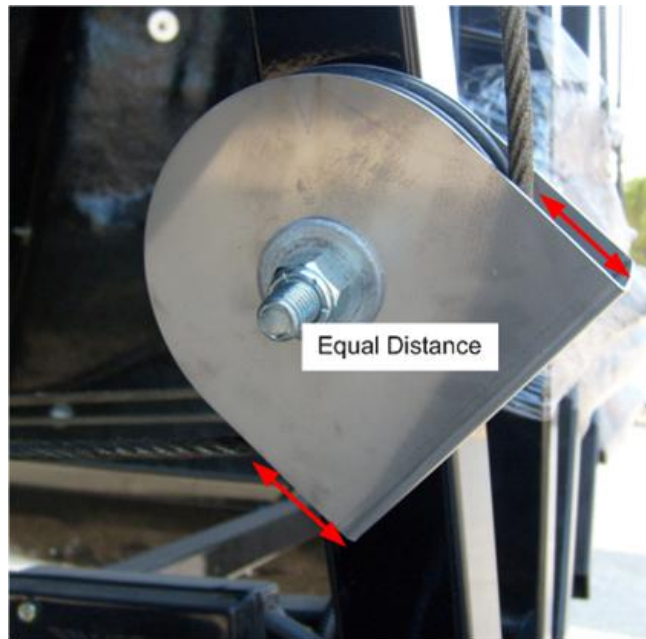

With the davit pulley shield held in the proper place, tighten the nylock nut and bolt using two SAE 3/4" wrenches or sockets.

12.12. Re-Pressurize The Auto-belay Air/Oil Tank

Prior to adding air, pull the end of the cable with the swivel down to its respective eye-bolt at the bottom of the climbing wall panel. Attach the cable swivel to the eye-bolt with the carabiner.

The auto-belay air fill Valve accepts a standard automotive style tire air chuck for adding air pressure.

When pressurizing the Auto-belay, any slack in the cable will retract back into the Auto-belay. Ensure the cable doesn't get caught on yourself or your clothing during the adding of air pressure when the cable retracts into the auto-belay. The cable can retract very quickly, without warning, at some point during the adding of air pressure.

Slowly raise the air pressure in the tank to 65 psi as indicated on the auto-belay pressure gauge near the air fill valve. The proper air pressure operational range is between 60 and 65 psi as indicated on the auto-belay pressure gauge with the cable extended to the eye-bolt. Replace the black plastic air fill valve cap onto the air fill valve.



Note: for AB-34. AB-52 is 75-85 PSI.

12.13. Auto-belay Operational Safety Inspection

After replacing all cables, perform section 4 to verify Auto-belay operation and to **Prime Before You Climb**.

The following day or before the wall is used the first time after a cable replacement, check the auto-belay for excessive air loss as indicated on the air pressure gauge as well as excessive oil leakage from anywhere on the auto-belay system.

There may be a small amount of excessive oil leakage initially as a result of releasing the air pressure from the auto-belay system during the cable swap. Clean up any oil residue that may have appeared and follow the procedure for determining excessive leakage as found in under Safety Inspection Of Internal Components in this manual.

ALWAYS REMEMBER “PRIME BEFORE YOU CLIMB”

Reference section 4 for proper set up procedures and for following the **Prime Before You Climb** after replacing cables or parts on an auto-belay.

13. Cleaning And Other Special Care

Wall and trailer

Clean the mobile climbing wall as you would a boat, camper or recreational vehicle. Hose it off. Use a solution of warm water and dish soap to remove dirt from the wall and trailer.

Carabiners

Keep carabiners dry and clean. Protect them from corrosion. DO NOT store them in very humid or salty air, with damp equipment or clothing, or near corrosive chemicals. DO NOT file carabineers for any reason. If notches appear, replace the carabineer. If a carabiner gate sticks, wash it in warm soapy water, rinse thoroughly and lubricate with either dry graphite or Teflon lubricant around the hinge area, inside the spring hole and locking mechanism.

Harnesses

Hand-wash a dirty harness in cool water with a mild soap. Allow it to dry in a shaded area.

13.1. Protection From The Elements

Store the mobile climbing wall as you would a boat, camper or recreational vehicle.

Storing the mobile climbing wall in a covered shelter or garage will keep it cleaner and preserve its appearance longer.

Storing the mobile climbing wall outdoors is no problem. However, you may want to place a tarp over it to preserve the finish from excessive exposure to the sun. To prevent damage, the tarp needs to allow air circulation. Trapping moisture under a polypropylene tarp can lead to rust or corrosion damage of components.

DO NOT store harnesses for extended periods in direct sunlight

14. Quick Checklists And Log

On the next three pages you will find condensed maintenance checklists, plus a maintenance log sheet, which you can photocopy and use.

14.1. Per-Use Maintenance Checklist

Auto-belay cables

Check for kinks, wear or damage to the cable. Never repair or mend, always replace suspected cables.

Check for fraying or broken strands

Check for kinks, wear or damage to the cable. Never repair or mend, always replace suspected cables.

Auto-belay pulleys.

Must not be worn, and must turn smoothly.

Air Tank

Check that pressure is at 60 to 65 psi (Mobile 2, 3, 4 and 5 climber models) or 75 to 85 psi (Mobile 5 Climber 35 foot) (or as marked on tank).

Hydraulic hose

Check for leaks at ram or pump ends.

Trailer lights

Tail, brake, running, turn signal lights should be working.

Trailer tires

Pressure at 50 psi (factory original or duplicate replacement) or to manufacturer's specifications. Tread must be adequate, with no objects in treads. Also check the spare tire.

Keeper pins

Be sure spares are on hand.

Harnesses

Must be in good condition, not worn. When dirty, hand wash in cool water, and dry in a shaded area (not in direct sunlight).

Carabiners

Check for bent, loose, or missing rivets. The gate/lock must close freely. If gummed up, clean with soapy water and dry.

14.2. Periodic Maintenance Checklist

Thoroughly inspect the mobile climbing wall before every use.

- **Do the per-use maintenance checklist first.**
- **Loose or broken parts.** Replace broken parts; tighten loose parts.
- **Trailer hitch.** Be sure the hitch, hitch lock, and light/brake cable all are operating correctly. Be sure the safety cable is OK.
- **Trailer tongue.** Make sure the bolts are tight.
- **Trailer wheels.** Make sure lug nuts are tight.
- **Trailer electric brakes.** Check for correct operation of the brakes and breakaway switch.

- **Jacks.** Extend all jacks and clean inner ram tubes. Coat with silicon spray lubricant.
- **Wall lift system.** Be sure the wall lifts smoothly. Check that connectors on the hydraulic lift pump are tight (control cable, power, and ground). Tighten if needed.
- **Battery.** Check terminals for corrosion; clean if needed.
- **Auto-belay system.** Cable slack is taken up, and paid out correctly. Also make sure that the cable is free of broken strands, corrosion, rust, frays, or any other defects.
- **Clean wall and trailer.** Wash with soap and water.

15. Safe Towing Tips

We encourage you to be a safe, courteous driver when towing your mobile climbing wall. Keep the following in mind when towing your wall on public streets.

Be sure that the lug nuts are tightened.

Be sure to use the safety cable at all times.

Be sure the tail lights, brake lights, and turn signals are functioning correctly.

Be sure the trailer's brakes are working correctly.

Be sure your trailer is properly registered with your state motor vehicle department.

Always observe the posted speed limits for trailers when towing your mobile climbing wall, and be especially cautious (and reduce your speed) when encountering windy, snowy, or rainy conditions.

Install extended side rear view mirrors on your towing vehicle. Your mobile climbing wall is over 24 feet in length and you'll need the mirrors to see traffic directly behind you.

Signal before changing lanes. When you change lanes, be aware of traffic behind you and at your sides. Allow plenty of clearance before changing lanes.

DO NOT attempt to make tight left or right turns.

Practice backing up where there is plenty of room before you try it in a real-life situation. To back up a trailer, turn the steering wheel the opposite direction from the direction you want the trailer to move.

16. Specifications

16.1. Five-Climber Specifications

| | |
|-------------------------------------|--|
| Overall Length | 28' (8.54 M) tow tongue to bottom of tower frame |
| Height Raised | 28' (8.54 M) tow tongue to bottom of tower frame |
| Height Lowered | 10' (3.05 M) wall horizontal, highest point |
| Overall Width | 9' (2.75 M) outside davit arms on tower frame |
| Trailer Base Width | 7' (2.14 M) rear jacks removed |
| Climbing Panel Height | 24' (7.32 M) |
| Unladen Weight | 4200 Lbs (1905.09 Kgs) |
| Maximum Gross Vehicle Weight | 7000 Lbs (3175.15 Kgs) |
| Unladen Tongue Weight | 400 Lbs (181.45 Kgs) |
| Trailer Type | Space Saver™ Tandem Axle with Fenders |
| Axles | 3,500 Lbs (1587.6 Kgs) maximum load PER Axle 4" Drop Heavy duty tapered roller bearings 4 leaf springs One rear brake axle One front idler axle |
| Brakes | Dual electric brakes on rear axle |
| Hitch Requirements | Class 3 – 5000 Lbs (2268.0 Kgs) Class 4 – 7000 Lbs (3175.15 Kgs) Maximum Gross Vehicle Weights |
| Coupler Specifications | 12,000 Lbs (5443.1 Kgs) rated Type – Formed bolt-on Ball Diameter – 2-5/16" (58.75 Mm) Grade 8 Bolt Torque – 150 Ft-lbs (20.74 Kg-m) |
| Wheel Specifications | 15" (381 Mm) diameter 4-1/2" (114.3 Mm) bolt pattern |
| Tire Specifications | ST205 / 75 D15 Carlisle, trailer rated (may change without notice) Load Range C Maximum Load 1820 Lbs (825 Kgs) at 50 PSI (345 kPa) Cold |
| Tire pressure | 50 psi (345 kPa) Cold |
| Wiring | Standard RV 7-Way towing plug 12 Volt DC |

16.2. Four-Climber Specifications – SAE (Metric)

| | |
|-------------------------------------|---|
| Overall Length | 29' 10" (9.1 M) tow tongue to bottom of tower frame |
| Height Raised | 29' 10" (9.1 M) tow tongue to bottom of tower frame |
| Height Lowered | 9' (2.75 M) wall horizontal, highest point |
| Overall Width | 8' (2.45 M) outside davit arms on tower frame |
| Trailer Base Width | 7' (2.14 M) rear jacks removed |
| Climbing Panel Height | 25' 6" (7.78 M) |
| Unladen Weight | 4000 Lbs (1814.38 Kgs) |
| Maximum Gross Vehicle Weight | 7000 Lbs (3175.15 Kgs) |
| Unladen Tongue Weight | 400 Lbs (181.45 Kgs) |
| Trailer Type | Space Saver™ Tandem Axle with Fenders |
| Axles | 3,500 Lbs (1587.6 Kgs) maximum load PER Axle 4" Drop Heavy duty tapered roller bearings 4 leaf springs One rear brake axle One front idler axle |
| Brakes | Dual electric brakes on rear axle |
| Hitch Requirements | Class 3 – 5000 Lbs (2268.0 Kgs) Class 4 – 7000 Lbs (3175.15 Kgs) Maximum Gross Vehicle Weight |
| Coupler Specifications | 12,000 Lbs (5443.1 Kgs) rated Type – Formed bolt-on Ball Diameter – 2-5/16" (58.75 Mm) Grade 8 Bolt Torque – 150 Ft-lbs (20.74 Kg-m) |
| Wheel Specifications | 15" (381 Mm) diameter 4-1/2" (114.3 Mm) bolt pattern |
| Tire Specifications | ST205 / 75 D15 Carlisle, trailer rated (may change without notice) Load Range C Maximum Load 1820 Lbs (825 Kgs) at 50 PSI (345 kPa) Cold |
| Tire pressure | 50 psi (345 kPa) Cold |
| Wiring | Standard RV 7-Way towing plug 12 Volt DC |

16.3. Three-Climber Specifications – SAE (Metric)

| | |
|-------------------------------------|---|
| Overall Length | 27' 6" (8.38 M) tow tongue to bottom of tower frame |
| Height Raised | 27' 6" (8.38 M) tow tongue to bottom of tower frame |
| Height Lowered | 7' 3" (2.21 M) wall horizontal, highest point |
| Overall Width | 7' 10" (2.34 M) |
| Trailer Base Width | 7' 10" (2.34 M) |
| Climbing Panel Height | 24' (7.32 M) |
| Unladen Weight | 3200 Lbs (1451.5 Kgs) |
| Maximum Gross Vehicle Weight | 3500 Lbs (1587.6 Kgs) |
| Unladen Tongue Weight | 400 Lbs (181.45 Kgs) |
| Trailer Type | Space Saver™ Single Axle with Fenders |
| Axle | 3,500 Lbs (1587.6 Kgs) maximum load 4" Drop Heavy duty tapered roller bearings 4 leaf springs Brake axle |
| Brakes | Electric brakes |
| Hitch Requirements | Class 3 – 5000 Lbs (2268.0 Kgs) Class 4 – 7000 Lbs (3175.15 Kgs) Maximum Gross Vehicle Weight |
| Coupler Specifications | 12,000 Lbs (5443.1 Kgs) rated Type – Formed bolt-on Ball Diameter – 2-5/16" (58.75 Mm) Grade 8 Bolt Torque – 150 Ft-lbs (20.74 Kg-m) |
| Wheel Specifications | 15" (381 Mm) diameter 4-1/2" (114.3 Mm) bolt pattern |
| Tire Specifications | ST205 / 75 D15 Carlisle, trailer rated (may change without notice) Load Range C Maximum Load 1820 Lbs (825 Kgs) at 50 PSI (345 kPa) Cold |
| Tire pressure | 50 psi (345 kPa) Cold |
| Wiring | Standard RV 7-Way towing plug 12 Volt DC |

16.4. Steel Framing and Weld Specifications

| | |
|----------------------|--|
| Steel Framing | Tubing is ASTM A500 Flat plate is ASTM A572 |
| Welds | Welding is American Welding Society and A15C |

16.5. Mobile Wall Lift Pump Specifications

| | |
|------------------|--|
| Lift Pump | 12 Volt Hydraulic Dextron III/Mercon Automatic Transmission oil Filled capacity 10 quarts Powered up and powered down |
|------------------|--|

16.6. Auto-belay BELAY IN THE BOX™ Specifications

| | |
|---------------------------------|--|
| Hydraulics | Fully redundant Heavy-duty welded hydraulic cylinders 1-1/2" diameter cylinders Dual check valves and cylinders Air (cable retraction) and Hydraulic (cable extension) |
| Air tank pressure | 60 to 65 PSI (cable extended to eye-bolt at bottom of climbing panel) – Models 2, 3, 4 and 5 climbers 75 to 85 PSI (cable extended to eye-bolt at bottom of climbing panel) – Model 5 climber 35 foot. |
| Oil Type | Dextron III/Mercon Automatic Transmission Oil Filled capacity 6 quarts |
| Belay in the Box™ system | Redundant air/oil (pneumatic over hydraulic) Engineering-grade polymer pulleys Certified 7,000 lb tensile test cable Integral swivel (attached to cable) Stainless steel pulley shields US Patent # 6,390,952 |
| Climber Capacity | one per each Auto-belay™ |
| Weight Limits | 45 – 250 lbs (harness capacity) |

17. Wiring Diagrams

LIFT CONTROLLER WIRING DIAGRAM (Black controller)

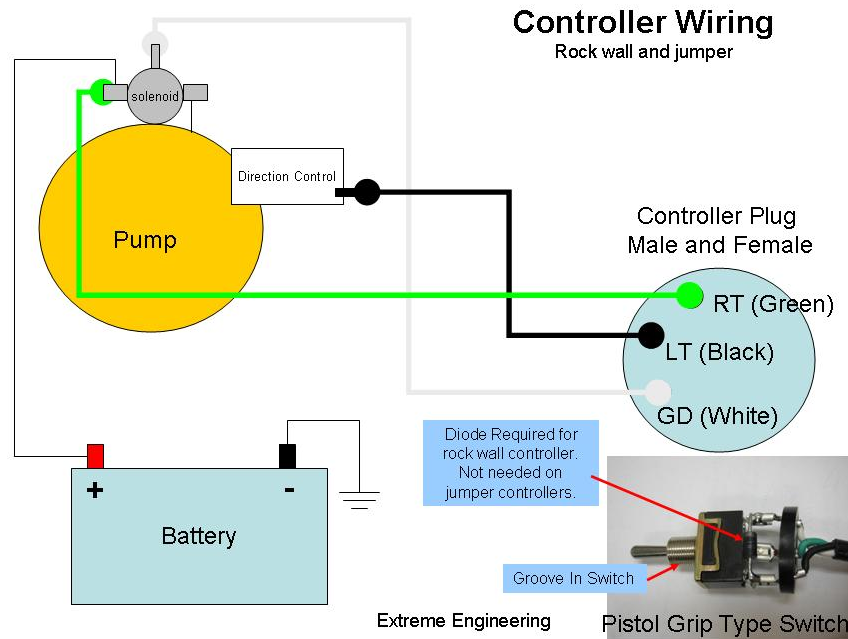

Trailer side Connector

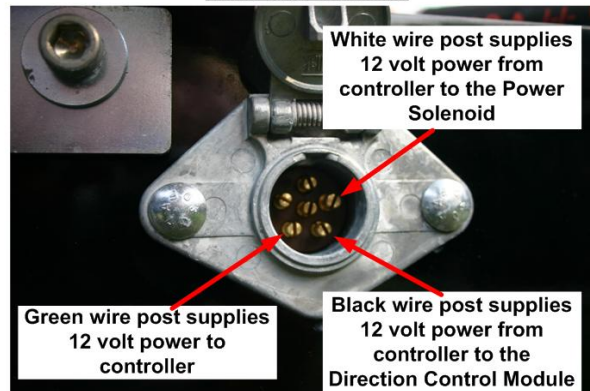

Controller Side Connector

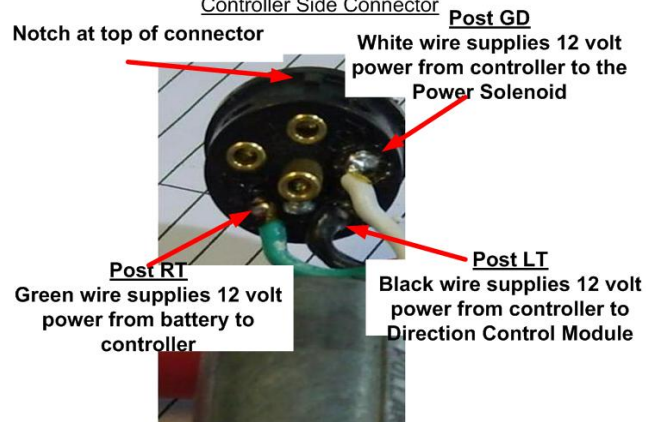

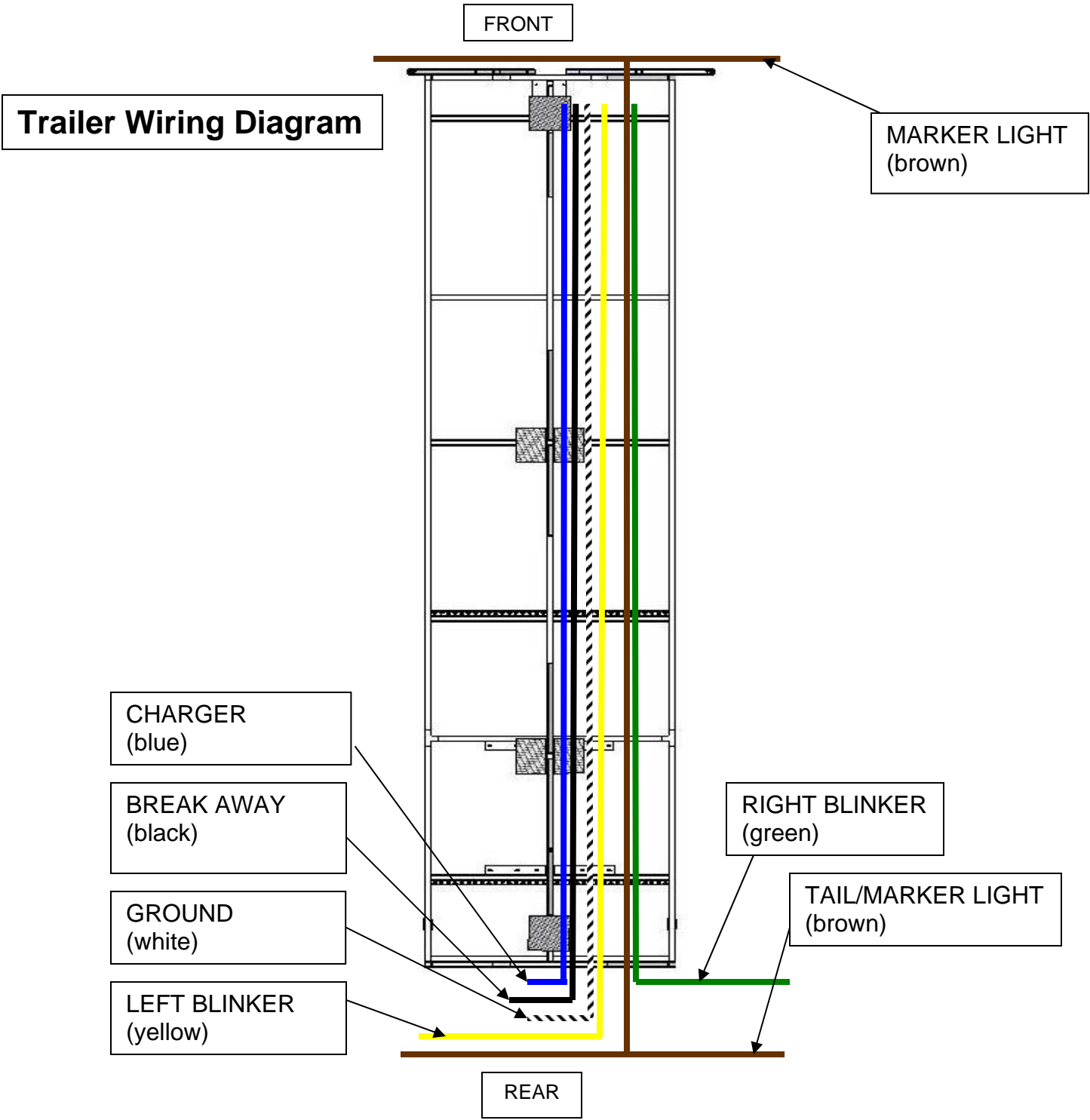

18. Battery Maintenance



WARNING: Testing electrical components can cause them to fail or burn out if the testing is not performed carefully and properly. Extreme Engineering is not responsible for any damages to electronic devices as a result of improper handling and/or testing of components.



CAUTION: Performing battery maintenance requires extreme care. Always wear protective equipment (e.g. safety glasses/goggles) and clothing (e.g. gloves) when working around lead acid batteries. The battery acid is highly caustic and can cause severe injury as well as damage to clothing, paint and other materials if not properly handled. If you are unsure of proper handling and maintenance techniques for these types of batteries, have a trained professional perform the required actions.



CAUTION: When replacing, repairing, or performing maintenance on batteries or electrical systems operated by the battery, always disconnect the negative (-) battery cable first prior to performing any other actions. This will prevent possible damage to electrical parts or self injury due to the potential of sparks that can be generated by the electrical power. Always re-attach the negative battery cable as the final action.



CAUTION: Always perform maintenance on batteries in a well ventilated area and well away from all flammable liquids and vapors (e.g. paint, gasoline, aerosol spray cans, etc). Unexpected sparks from the battery or electrical components can cause flammable liquids and/or vapors to ignite causing severe fire hazards.



CAUTION: Pressure buildup during charging can cause the battery to explode if the battery cell caps are not removed while charging.

Battery maintenance consists of the following actions:

Check the liquid level in the battery for proper fill. If water must be added, DO NOT Use tap water. Instead, use distilled water. The water level must cover the lead plates inside each compartment of the battery completely. These plates may be visible when the fill caps are removed. Most batteries provide a full level indicator inside at the bottom of the fill hole. DO NOT overfill the battery cells. Each cell is a separate compartment inside the battery. Therefore, each cell must have their caps removed for checking and filling.

Check all the battery cables and wires where they attach to the posts on the battery for corrosion and/or acid buildup. The cables, wires and posts should be kept free from this buildup. A solution of water and baking soda can be sprayed onto acid buildup to neutralize the acid. It may take several passes with spraying the solution before the acid is completely neutralized. Once the acid is fully neutralized, the cables can be removed from their attaching posts and any remaining acid can be removed by brushing it away with a wire brush. Automotive stores sell sets of small green and red disks coated with an acid preventative solution which helps to control acid buildup.

Check for damage to the outside of the battery casing. If damaged, replace the battery.

Check for fluid leakage other than around the fill caps. If leakage is found, replace the battery.

Periodic charging must be performed. It is recommended to charge the battery frequently, preferably after each day's use, with a Smart Charger battery charger.

18.1. Marine Deep Cycle Battery Required

Extreme Engineering utilizes a Deep Cycle, Group 27, 12 Volt DC, Marine Battery rated for use with boat trolling motors on all mobile wall products.

The purpose of this type of battery is to supply electricity for a given period of time before it needs to be recharged. This is different than one designed for automotive engine starting which requires high current demands for a short period of time. The deep cycle battery cannot supply high current demands but can supply lesser current for a longer period of time without damage.

Operating for extended lengths of time at less than full charge with deeper discharges causes increased build up on the plates inside the battery. This build up prevents electricity from flowing and therefore provides less and less power over time.

Therefore, deep cycle batteries require maintenance.

Recharge as soon as possible after each use and maintain the State of Charge at 100% to prevent permanent build-up on the internal battery lead plates.

When in storage, continuous float charging (charging at low current, about 1 amp) is the best way to prevent build-up. Or recharge before the State-of-Charge drops to 80%. Build-up kills over 80% of deep cycle batteries.

Reducing the average Depth-of-Discharge (DoD) will significantly increase a deep cycle battery's life. For example, a battery with an average of 50% DoD will last twice as long or more as an 80% DoD; a 20% DoD will last five times longer than a 50% DoD. Try to avoid DoD that are greater than 80%. Industrial, traction, and stationary deep cycle batteries with solid lead plates are designed for average of 80% DoD and most Marine/RV designed for average 50% DoD.

Never discharge below 10.5 volts.

18.2. Battery Operation

A fully charged new battery of the proper type can provide from five and to eight lift/lower cycles between charging. Under normal usage, even with periodic maintenance and charging, the number of lift/lower cycles will reduce over time. Eventually, the battery will not be able to operate the wall at all and must be replaced. This is a normal condition.

The default mode of the pump is to raise the wall. The Direction Control Module reverses the flow direction of the automatic transmission oil and this causes the wall to lower when the controller's down mode is initiated by the wall operator. As the voltage supplied from the battery drops, the wall will begin to raise slower than normal. With continued use without charging, as the battery supplies less and less voltage, the wall may raise successfully but the wall may not lower completely or may not lower at all. This is because

there may be enough power from the battery to operate the pump motor but not enough power to operate both the Direction Control Module and the pump motor at the same time.

When the voltage supplied from the battery begins to decrease below a specific level of voltage, this will result in less efficient operation of the pump. This also causes excessive heat generation throughout the whole electrical system during operation. This excessive heat can cause the electrical components, including the pump motor, to fail and require replacement. The reduced efficiency, excessive heat generation and possible component failure is not isolated to just Extreme Engineering mobile walls. This condition is the same for any product which utilizes this style of battery.

To ensure the mobile wall operates properly, Extreme Engineering recommends the battery be replaced at the start of the customer's operating season annually.

A weak battery can cause problems with raising and lowering the wall demonstrating symptoms similar to possible controller issues, pump issues or hydraulic issues. Before troubleshooting any of these other areas, have the battery tested to ensure all cells are good, the electrolyte level is appropriate for the battery, and the battery can take and maintain a full charge for a proper period of time.

18.3. Battery Charging

The battery should be charged on a regular basis. Ideally, the battery should be fully charged after every use. The negative (-) battery cable should be disconnected from the battery while charging. Remove the battery cell caps to prevent pressure buildup inside the battery during charging. This pressure buildup can be significant enough to cause the battery to explode during charging.

For factory supplied batteries, if the battery charger has a setting for battery types, set it to the wet cell position.

Extreme Engineering adds the capability to maintain the battery charge from the tow vehicle on Three-, Four- and Five-Climber models. The Two-Climber model does not have this capability. This is accomplished through the electrical connection between the mobile wall and the tow vehicle using the standard Recreational Vehicle 7-Wire configuration via the black 12V (black/red) as seen in the below diagram.

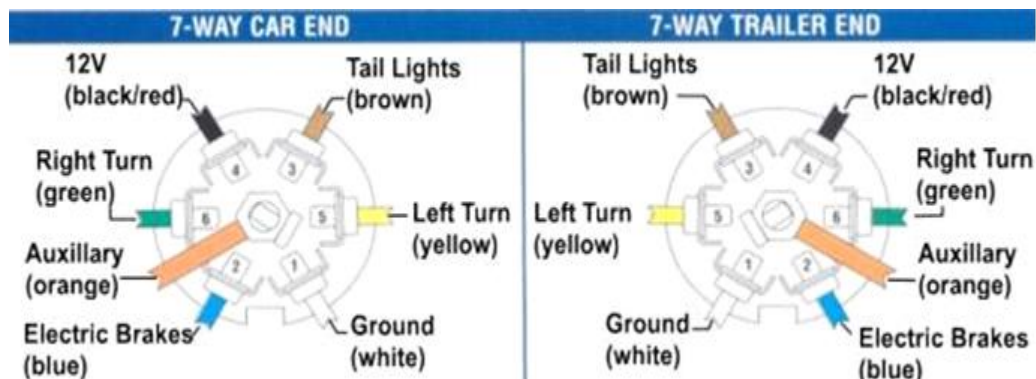

RV 7-Wire Wiring Diagram

Note: Even though the battery receives a charge voltage from the tow vehicle during towing, a battery may not be properly recharged to a sufficient level while the mobile wall is being towed. To achieve a proper charge for the battery, the towing vehicle would potentially need to tow the wall for several hundred miles. Even then, the battery may not have a sufficient charge for raising and lowering the climbing wall.

18.4. What is and Why Use a “Smart Charger”

Extreme Engineering recommends using a battery charger that contains Smart Charger technology.

Why use a Smart Charger?

Smart Chargers DO NOT have any timers. All decisions are based on the battery’s voltage and current. The charger may stay in either of the below first two states as long as necessary to achieve a proper battery charge.

Smart Chargers output pure DC output which provides a faster, more complete and stable charge. Many conventional chargers output pulsating DC current which is significantly below rated amperage specifications.

A Smart Battery Charger has three distinct operating stages.

At stage one (Bulk/Rapid mode), the charger limits the maximum charging current to a preset value while monitoring the battery voltage. Faster than conventional type chargers, even in freezing or high temperatures, the charger delivers maximum charging amperage to "wake up" any 12 Volt battery quickly. When it reaches a maximum safe predetermined voltage, digital sensors automatically move into stage two of the charging process.

In stage two (Absorption mode), the charger elevates the voltage to a preset maximum value while monitoring the current. The charger maintains the maximum possible charge at a constant safe predetermined voltage. During this stage two charging, the charging voltage remains constant, while the actual charging current is reduced to allow for the maximum proper internal chemical energy transfer. When the current decreases (tapers down) to a preset value, the charger enters stage three mode.

In stage three (Maintenance mode), the charger will vary current from none to a preset maximum current while maintaining the battery at full voltage charge. Voltage is automatically maintained and reduced to a predetermined level while current is adjusted for a safe, effective 100% charge (step-down regulation mode). This is ideal for topping off batteries that have been in storage. The Maintenance mode Is Not a trickle mode. The charger will issue Zero current if the battery accepts proper charge during the first two modes. This feature allows the charger to be connected indefinitely and it will not overcharge (or trickle charge) the battery. With automatic shut-off at 100% charge, you can trust the charger to never overcharge any battery.

Note: The current must be allowed to decrease down to the chargers pre-defined amperage in order for the charger to enter the Maintenance mode. If your installation has a load on the battery in excess of this pre-defined amperage, the charger may stay in the Absorption mode and never enter Maintenance mode.

With some Smart Chargers, if you connect a battery that contains less than the charger's pre-defined minimum voltage (typically 6 volts), the charger may assume there is a defect in the battery and it will not attempt to charge. Likewise if you turn the charger on without a battery connected, the charger may not output any voltage/current. This is a safety feature which prevents output short circuits. They also have reverse hook-up protection to prevent short circuits.

Smart Chargers can compensate for temperature variations. At elevated temperatures, all voltages are lower. Likewise at colder temperatures, all voltages are higher. Normal operation of the charger assumes the battery and charger are in the same environment.

Always read and follow the manufacturer's instructions for your battery charger.

19. Limited Warranty

EXTREME ENGINEERING warrants to the first consumer purchaser that this product will be free from defective workmanship and materials. This warranty is nontransferable.

Warranty is subject to the following conditions:

1. Extreme Engineering agrees that it will, at its option, either repair or replace a defective part or will, at its option, repair or replace the defective product, at no charge to the purchaser for labor for a period of ninety (90) days, at factory, from date of delivery, and at no charge to the purchaser for parts for a period of one (1) year from date of delivery (shipping and handling costs will apply). The consumer purchaser will have the following options when exchanging warranted parts: 1. The consumer purchaser will have to send the defective part or product back to Extreme Engineering's manufacturing plant. The defective part or product will be determined by Extreme Engineering if it is defective. Extreme Engineering will send a replacement part free of charge if the part or product is found defective. or 2. The consumer purchaser will initially be charged for the warranted part or product. Once Extreme Engineering receives the defective part or product the consumer purchaser will be credited back if the part or product is found to be defective. Consumables are covered for 30 days (harnesses, auto-belay cables, pulleys, carabiners, etc.). You may contact Extreme Engineering for additional details on consumable items. We have a 90-day warranty on electronics, 30-days on labor, 90-day on parts. Auto-belay™ systems are warranted for the original purchaser(s) for one year (does not cables).
2. This limited warranty is valid only when the product is installed, operated and maintained in accordance with the Extreme Engineering Owner's Manual. Any deviation from these recommended procedures must be approved in writing by Extreme Engineering.
3. This limited warranty does not apply to any part which has been subjected to misuse, abnormal service or handling or which has been altered or modified in design or construction.
4. This limited warranty does not apply to changes in the exterior appearance of the mobile climbing wall™. Custom painted products are not covered by Extreme Engineering's limited warranty.

4. Neither the sales personnel of the seller nor any other person is authorized to make any warranties other than those described herein or to extend the duration of any warranties beyond the time period described, on behalf of Extreme Engineering.
5. Do Not book events until arrival of Extreme Engineering equipment. Extreme Engineering is not responsible for lost revenue from events booked prior to final delivery of equipment. Extreme Engineering is also not responsible for lost revenue due to unforeseen delays in shipment or delivery of Extreme Engineering equipment.
6. Customer agrees to use OEM parts when servicing an Extreme Engineering product. If Customer fails to abide by this term the product warranty will void and Extreme Engineering will not be responsible for failure of proper operation of an Extreme Engineering product.
7. By operating this product, customer promises to operate and use any equipment in accordance with all owner's manuals service recommendations, service bulletins, recommendations and safety tips which Customer has received or may receive in the future in accordance with sound and accepted safety practices and according to applicable laws and regulations. Customer agrees that only trained and qualified staff or personnel shall supervise the use and operation of the equipment. Customer acknowledges that it has received reviewed and understands Extreme Engineering's Owner's Manual and agrees to operate the equipment in accordance with the instructions provided therein.
8. (a) With the exception that this section shall in no event be construed to require indemnification by Customer to a greater extent than permitted under applicable law, Customer shall defend, indemnify, and hold harmless Extreme Engineering, including Extreme Engineering's officers, agents, employees, parents, and subsidiaries, and each of them, of and from any and all claims, demands, causes of action, damages, costs, expenses, actual attorneys' fees, losses or liabilities, in law or in equity, of every kind and nature whatsoever ("Claims") arising out of or related to Customer's operations, including but not limited to:
 - (i) Personal injury, including, but not limited to, bodily injury, emotional injury, loss of consortium or death to any person caused or alleged to be caused in whole or in part by any act or omission of Extreme Engineering, Customer or anyone directly or indirectly employed by Customer regardless of whether such personal injury or damage is caused by a party indemnified hereunder.
 - (ii) Penalties imposed on account of the violation of any law, ordinance, citation, rule, regulation, standard, ordinance, or statute, caused by the action or inaction of Customer or anyone directly or indirectly employed by Customer.
 - (iii) Any violations or infraction by Customer of any law, order, citation, rule, regulation, standard, ordinance, or statute in any way relating to the occupational health or safety of employees, including, but not limited to, the use of Extreme Engineering's or others' equipment, hoists, elevators, or scaffolds.
 - (ix) Any failure or alleged failure to comply with the terms of this Customer Contract.

Customer, however, shall not be obligated under this Customer Contract to indemnify Extreme Engineering for Claims arising from the sole negligence or willful misconduct of Extreme Engineering or its agents, employees or independent contractors.

(b) Customer shall:

(i) At Customer's own cost, expense, and risk, defend all Claims as defined above that may be brought or instituted by third persons, including, but not limited to, overnmental agencies or employees of Customer, against Extreme Engineering or its agents or employees or any of them;

(ii) Pay and satisfy any judgment or decree that may be rendered against Extreme Engineering or Owner or their agents or employees, or any of them, arising out of any such Claim;

(1) Reimburse Extreme Engineering, its agents an employees for any and all legal expense incurred by any of them in connection herewith or in enforcing the indemnity granted in this Section (a). Nothing contained in this Customer Contract shall be deemed to obligate the Customer to indemnify the indemnified parties against liability for damages or any other loss, damage or expense sustained, suffered or incurred on account of death or bodily injury to persons or damage to property caused by the sole negligence or willful misconduct of the indemnified parties.

(2) Extreme Engineering is not responsible for Acts of God.

All of the terms and conditions of this operating manual shall become binding when used by an authorized representative of the Customer.

7. THE WARRANTIES DESCRIBED HERE SHALL BE THE SOLE AND EXCLUSIVE WARRANTIES GRANTED BY EXTREME ENGINEERING AND SHALL BE THE SOLE AND EXCLUSIVE REMEDY AVAILABLE TO THE ORIGINAL PURCHASER. Correction of defects, in the manner and for the period of time described here, shall constitute complete fulfillment of all liabilities and responsibilities, whether based on contact, negligence, strict liability or otherwise. In no event shall Extreme Engineering be liable, or in any way responsible, for damages or defects in the product which were caused by repairs performed by anyone other than an authorized servicer.

8. Extreme Engineering shall not be liable, or in any way responsible, for incidental or consequential economic or property damage.

9. Technical support is available to the original purchaser up to one year from the purchase date of an Extreme Engineering product. Technical support outside of the one year warranty period is available for a fee.

19.1. Warranty Claim

In the event of a warranty claim, please fill out the warranty claim page located on the last page of this manual. You may download a copy from Extreme Engineering's technical support page at www.extremeengineering.com. You may also call Extreme Engineering for a copy of the warranty claim form. The warranty claim form must be filled out and sent with the defective product. You may also fax a copy to Extreme Engineering's Customer Service Department at 916-663-9249. You may contact customer service at 916-663-1560.

Warranty claim service must be performed and approved by the Extreme Engineering Customer Service Department. Warranty replacement hardware systems and components or parts will be free of charge. Shipping and handling costs on defective items returned to Extreme Engineering are paid by the consumer purchaser. Labor cost to repair or replace will be limited to the amount of the original purchase price of the systems and components. The replaced warranty products or parts become the property of Extreme Engineering and must be returned to the Extreme Engineering Customer Service Department freight prepaid, unless prior arrangements have been made.

20. Replacement Parts

Purchase your replacement parts through our customer support center at:
(916) 663-1560

or visit our online store at:

www.extremeengineering.com

Always make sure that your extreme products are running at optimal performance.

21. Technical Support

If you require technical support and your product is still under warranty, contact customer service to schedule free technical support on your product. Technical support will respond within 24 hours once a claim is placed.

You may call customer service at:
916-663-1560

or request a phone call through our website at:

www.extremeengineering.com

under the technical support page.



Warranty Claim Form

| | | | |
|---|--------|----------------|----------|
| Company Name: | | | Date: |
| Customer Name: | | | |
| Address: | | | |
| City: | State: | Zip: | Country: |
| Phone: | Fax: | | |
| Email: | | | |
| Product Name (Part Number): | | Purchase Date: | |
| Sales Order Number: | | | |
| Detailed Description of Current Issue(s): | | | |